



Brief Instruction *FLEXtra*[®] multiRepeater

Version

3_{en}

Application and functional description

The FLEXtra® multiRepeater is primarily a normal PROFIBUS Repeater with the expansion by 3 (for the 4-way) or 5 (for the 6-way) additional segments. This enables, e.g. the simple establishment of a PROFIBUS-star network. It regenerates the signals in flank slope, level and duty cycle.

Mounting

The FLEXtra® multiRepeater is suitable for mounting on a DIN rail. It is engaged as shown on the picture.

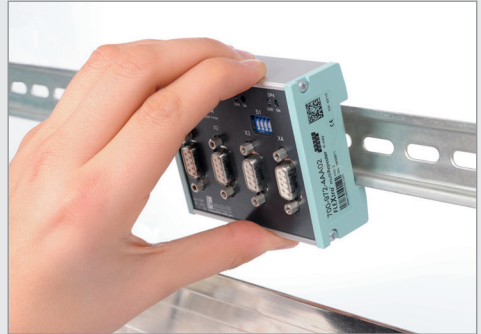

Switching repeat function

A DIP switch is installed for the deactivation of the repeat function on the individual ports. Furthermore, the respective last DIP switch i. e. DIP 5 (4-way) or DIP 7 (6-way), must be considered as OFF and ON switch for all segments.

Connection

The PROFIBUS is connected via the SUB-D female connector to the FLEXtra® multiRepeater. PROFIBUS connectors for each segment are necessary for this.



Connection of the power supply

The power supply of the device is connected using the power supply connections on the bottom left of the device. The assignment can be seen in the picture on the right.





























Terminating resistors

If the respective used port of the FLEXtra® multiRepeater is located at the end or beginning of a segment, the termination on the PROFIBUS connector must be activated (ON).

If the respective used port of the FLEXtra® multiRepeater is located in the middle of a segment, the termination on the PROFIBUS connector must be deactivated (OFF). Some examples can be found on the following pages.



LED description

	LED			DIP switch	
	PWR	DP 1–6		1–4 (4-way) 1–6 (6-way)	deactivated 5 (4-way) 7 (6-way)
	-ON-	-ERR-	-ON-		
Baud rate is detected, the FLEXtra® multiRepeater is restarted				ON	ON
Automatic restart e.g. in the case of signal loss				ON	ON
FLEXtra® multiRepeater ready for operation, baud rate detected				ON	ON
Segment switched off				OFF	ON
Repeat function deactivated for all segments				ON	OFF
Repeat function deactivated for all segments + individual segments				OFF	OFF
Invalid telegrams are received				ON	ON
There is a short circuit				ON	ON
Data is being received				ON	ON

Legend



LED on



LED flashes slowly



LED flashes quickly



LED off



LED on



Flash frequency depends on the number of invalid telegrams (steady light possible).



Flash frequency depends on baud rate and number of participants of the port (steady light possible).

Note: if no baud rate is detected, the repeater restarts every 8 seconds. The restart takes approx. 2 seconds.

Application examples

Example 1:

Extension of a bus.

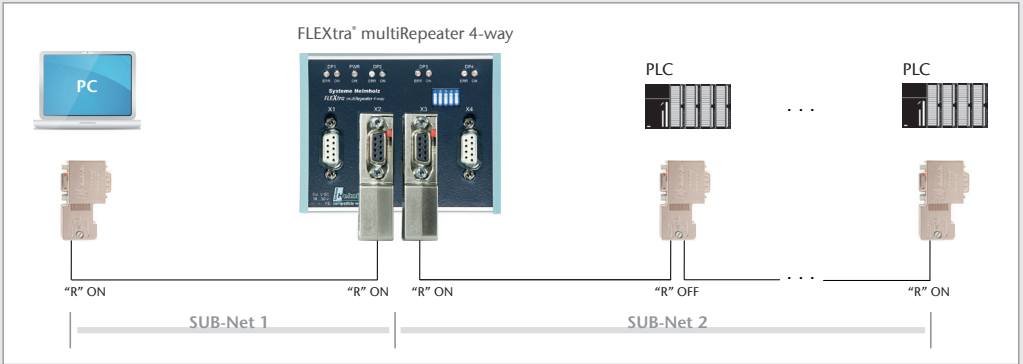

Example 2:

Complex tree bus structure.

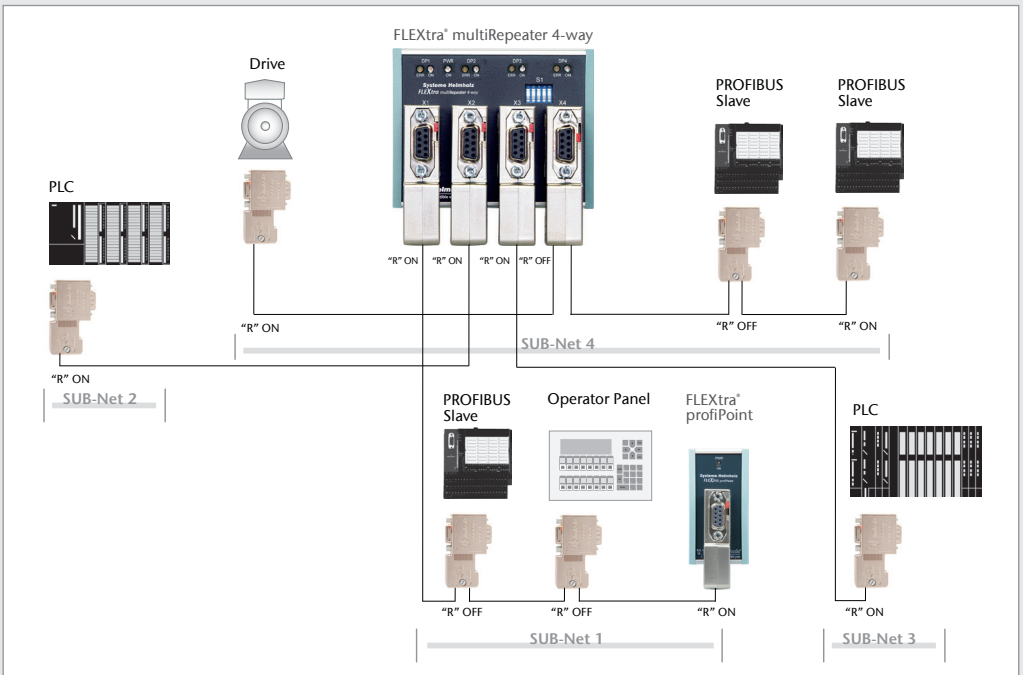

In all SUB networks up to 32 users are possible.

Application examples

Example 3:

Complex star structure.

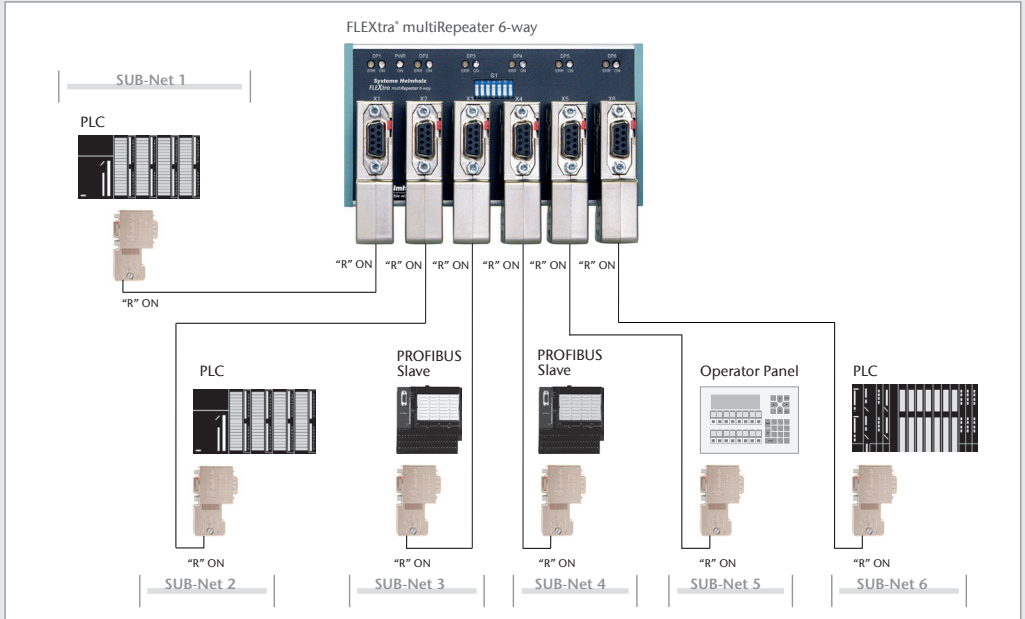

Example 4:

Extension by one line. The Compact Repeater can be used for this.

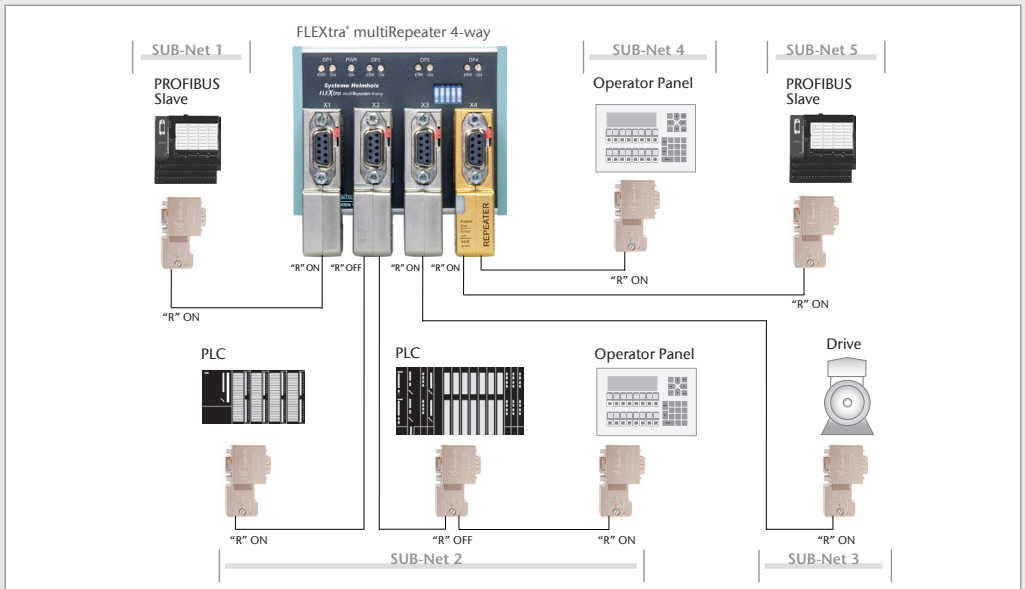

Technical Data FLEXtra® multiRepeater 4-way

Dimensions in mm (D x W x H)	72 x 94 x 35
Weight	approx. 180 g
Power supply	
• Voltage	+18 ... 30 V DC
• Electrical isolation	500 V
• Current consumption	
· incl. 5V-consumer load	max. 320 mA
· incl. 24V-consumer load	max. 1120 mA

Technical Data FLEXtra® multiRepeater 6-way

Dimensions in mm (D x W x H)	72 x 137 x 35
Weight	approx. 275 g
Power supply	
• Voltage	+18 ... 30 V DC
• Electrical isolation	500 V
• Current consumption	
· incl. 5V-consumer load	max. 480 mA
· incl. 24V-consumer load	max. 1680 mA

Technical Data of both FLEXtra® multiRepeater

Output voltage ports	
• Voltage 1	5 V, max. 150 mA
• Voltage 2	+18 ... 30 V DC, max. 200 mA (like supply voltage)
Permitted ambient conditions	
• Ambient temperature in operation	0°C ... +60°C
• Transport and storage temperature	-25°C ... +75°C
PROFIBUS Interface	
Transmission rate	9.6 19.2 45.45 93.75 187.5 500 kbps 1.5 3 6 und 12 Mbps automatic detection
Protocol PROFIBUS DP	according to EN 61 158-2:2011-09
Connection socket	
Ports	SUB-D 9-pin
Special features	Quality assurance according to ISO 9001:2008
Maintenance	maintenance-free, no battery

Note

We have checked the content of this Brief instruction for conformity with the hardware and software described. Nevertheless, because deviations cannot be ruled out, we cannot accept any liability for complete conformity. The information in this Brief instruction is regularly updated. When using purchased products, please heed the latest version of the Brief instruction, which can be viewed in the Internet at www.helmholz.com, from where it can also be downloaded.

Our customers are important to us. We are always glad to receive suggestions for improvement and ideas.