

MONO

MOTORI ELETTRICI MONOFASE
SINGLE PHASE MOTORS



DELPHI

MOTORI ELETTRICI TRIFASE
THREE PHASE MOTORS



manuale tecnico
technical manual

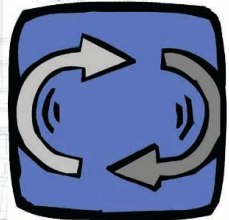
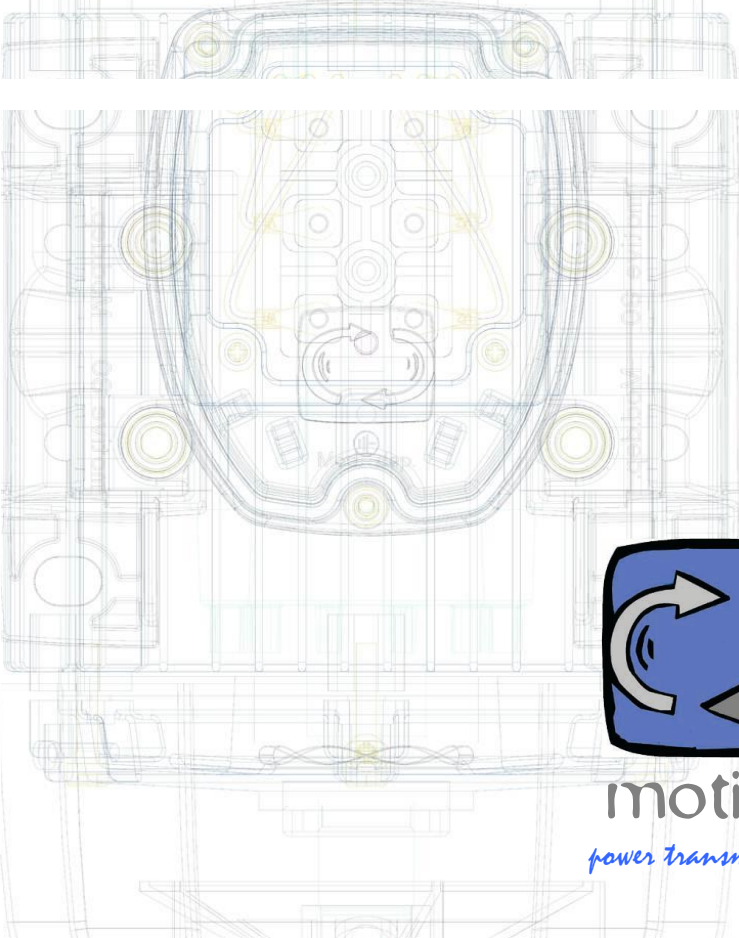

motive
power transmission



indice

Titolo

Caratteristiche tecniche
Protezioni elettriche e termiche
Collegamento elettrico
Schemi di collegamento
Messa in servizio
Condizioni di funzionamento
Tettuccio parapiovvia
Motori autofrenanti serie Delphi AT..
Motori servoventilati - serie SV
Encoder
Trasporto, conservazione, uso e manutenzione
Lubrificazione cuscinetti
Lista ricambi
Marcatura CE
Dichiarazione di conformità

index

title

Technical characteristics
Electrical and thermal protections
Electrical connection
Wiring diagrams
Start
Working conditions
Rain shield
Brake motors AT.. series
Assisted power cooling – SV series
Encoder
Transportation, conservation, use and maintenance
Bearings Lubrication
Spare parts list
CE marking
Conformity Declaration



Caratteristiche tecniche

I motori Motive DELPHI (trifase) e MONO (monofase) sono realizzati secondo le norme internazionali di unificazione ed adatti ad un uso universale; ogni dimensione, per tutte le forme costruttive, è stata dedotta facendo riferimento alle tabelle relative alla norma IEC 72-1;

Le forme costruttive realizzate, secondo IEC 34-7, sono B3, B5, B14, B3/B5, B3/B14, B14B

I motori asincroni trifase Motive sono di tipo chiuso, con ventilazione esterna.

La carcassa, fino al tipo 132 incluso, è ottenuta da pressofusione di lega d'alluminio, dal 160 in poi da fusioni in ghisa.

Tutti i dati di caratterizzazione dei motori, quali prestazioni e dimensioni sono dettagliatamente illustrati nel catalogo e nel sito www.motive.it.

Tutti i motori trifase sono multitenzione, e multifrequenza 50/60Hz secondo i valori esposti a destra

classe di isolamento F, servizio continuo S1*, protezione IP55.

Il rendimento è classificato in targa IE2/IE3 come da norma IE 60034-30

*S1 - Servizio continuo: funzionamento a carico costante.

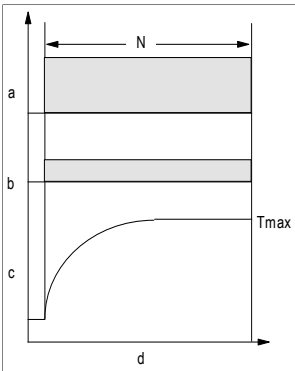

a= carico



b= perdite elettriche

c= temperature

d= tempo

N= tempo funzionamento a carico costante

Tmax= temperatura massima raggiunta

		Volts		
size	Hz			
		56-132	50	230
220	380			(Pn=100%)
240	415			(Pn=100%)
60	260		440	(Pn=110%)
	220		380	(Pn=100%)
	265		460	(Pn=115%)
		280	480	(Pn=120%)

132-400	50	400	690	(Pn=100%)
		380	660	(Pn=100%)
		415	720	(Pn=100%)
	60	440	760	(Pn=110%)
		380	660	(Pn=100%)
		460	795	(Pn=115%)
		480	830	(Pn=120%)



Technical characteristics

Motive motors are built according to international standard regulations for universal use; each size throughout the construction forms is calculated with reference to the tables of standard IEC 72-1;

The shapes built per IEC 34-7, are B3, B5, B14, B3/B5, B3/B14, B14B

Motive asynchronous three-phase are closed and externally ventilated.

The frame, up to 132 included, is made in die casting aluminium alloy, from 160 the frame is made in cast iron

All technical details, as performance data and dimensions, are thoroughly described in the product catalogue and in www.motive.it



All three-phase motors are multiple voltage, and multiple frequency 50/60Hz, according to the data on the right

F Class insulation, Continuous duty service S1*, IP55 protection
Efficiency is classified on the plate IE2/IE3 according to the norm IE 60034-30

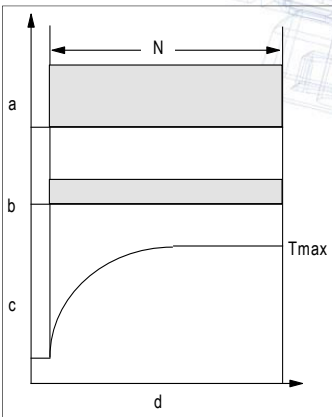
*S1 - Continuous duty service: operating at constant load



- a= load
- b= electric losses
- c= temperature
- d= time
- N= steady load operating time
- Tmax= max temperature achieved

		Volts		
size	Hz			
		56-132	50	230
220	380			(Pn=100%)
240	415			(Pn=100%)
60	260		440	(Pn=110%)
	220		380	(Pn=100%)
	265		460	(Pn=115%)
		280	480	(Pn=120%)
132-400	50	400	690	(Pn=100%)
		380	660	(Pn=100%)
		415	720	(Pn=100%)
	60	440	760	(Pn=110%)
		380	660	(Pn=100%)
		460	795	(Pn=115%)
		480	830	(Pn=120%)



Condizioni di funzionamento



Umidità: L'equipaggiamento elettrico deve essere in grado di funzionare con un'umidità relativa compresa tra il 30 ed il 95% (senza condensazione). Effetti dannosi di condensazioni occasionali devono essere evitati mediante un progetto adeguato dell'equipaggiamento oppure, se necessario, mediante misure aggiuntive (per es. scaldiglie incorporate per il riscaldamento, fori di drenaggio). Gli avvolgimenti sono impregnati a vuoto (vacuum) – procedimento VPI – senza evaporazione, e adatti perciò a climi tropicali

Altitudine e temperatura: le potenze indicate si intendono per motori la cui utilizzazione normale di funzionamento è prevista ad una altezza inferiore a 1000m sul livello del mare ed una temperatura ambiente compresa tra i -25°C e +40°C (IEC 34-1); per condizioni di esercizio diverse da quelle specificate (altitudine e/o temperatura superiori) la potenza diminuisce del 10% per ogni 10° di sovratemperatura, e dell'8% per ogni 1000 metri di altitudine in più. Non è consentito usare motori idonei all'utilizzo in atmosfere esplosive in ambienti con temperature fuori dal range -20°C +40°C.

Non è necessario ridurre la potenza nominale nel caso in cui ad una altitudine superiore ai 1000 m e inferiore ai 2000 m corrisponda una temperatura ambiente massima di 30°C o 19°C massimi per un funzionamento ad altitudini tra i 2000 m ed i 3000 m.

Tensione - Frequenza: È ammessa al massimo una variazione della tensione del +/-10% del valore nominale. In questo intervallo i ns motori forniscono la potenza nominale.

Nel funzionamento continuo, ai limiti di tensione sovraindicati, si può avere una fluttuazione della temperatura di riscaldamento fino a +/- 20°C max.

Gli avvolgimenti normali sono calcolati per tensioni di 400V e frequenza 50Hz.

Isolamento: l'avvolgimento dello statore è eseguito con filo di rame ed isolamento di cava in classe F, che garantisce una elevata protezione alle sollecitazioni elettriche e meccaniche.

Le temperature massime limite (Tmax) delle classi di isolamento definite dalle norme EN 60034-1 sono

Classe	ΔT (°C)	Tmax (°C)
A	60+5°	105
E	75+5°	120
B	80+5°	130
F	105+5°	155
H	125	180

I motori Motive, al fine di garantire un servizio continuo S1, sono costruiti in modo tale da avere un livello di riscaldamento classe B o inferiore, quindi ampiamente sotto il loro limite di protezione della classe F.



Working conditions



Humidity: The electrical equipment must be able to work with a relative humidity between 30 and 95% (without condensation). Damaging effects of occasional condensation must be avoided by adequate equipment design or, if necessary, by additional measures (for example, built-in heating device, drainage holes). The winding are vacuum pressure impregnated (VPI process, evaporation free, medium category), and are therefore suitable for tropical climates

Altitude and temperature: the powers indicated are intended for regular use at altitudes below 1000 mt above sea level and a temperature between -15°C and 40°C (IEC 34-1): For higher altitude and/or temperature the power decreases of 10% each 10°C of higher temperature, and of 8% for each 1000 mt of higher altitude. It is not allowed to use motors designed for explosive atmospheres in environment temperatures out of -20°C and +40°C range.

Voltage - Frequency: The maximum variation of the supply voltage is +/-10%. Within this tolerance Motive motors supply the rated power. Within such range, the temperature rise of the motor can fluctuate up to +/-20°C

Insulation: the stator winding is made of resin coated copper wire and insulation materials in F class, that provide high protection against electrical and mechanical stresses. The max temperatures (Tmax) for insulation classes defined by EN 60034-1 standard are

Class	ΔT (°C)	Tmax (°C)
A	60+5°	105
E	75+5°	120
B	80+5°	130
F	105+5°	155
H	125	180

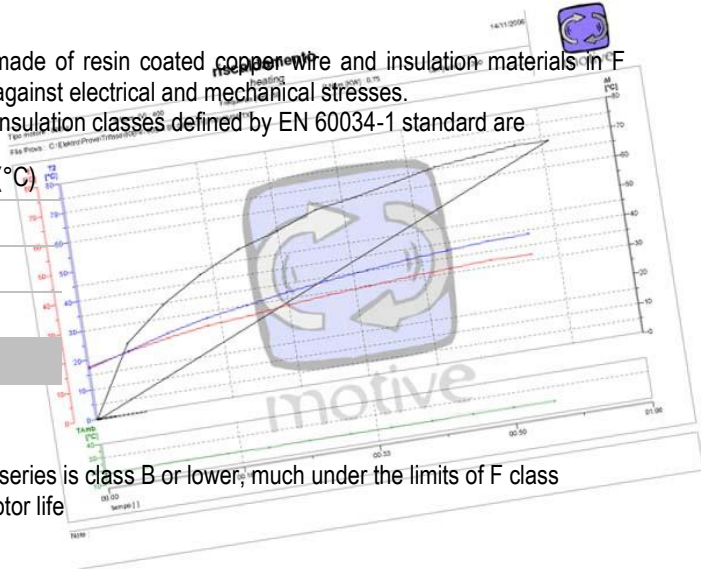

The temperature rise of the Delphi series is class B or lower, much under the limits of F class motors, thus permitting a longer motor life



Protezioni elettriche e termiche

Le protezioni devono essere scelte in base alle specifiche condizioni di esercizio secondo le norme EN 60204-1 (per motori destinati ad essere installati in atmosfere esplosive, vedi EN60079-14 ed EN61241-14).

Protezioni esterne

Si possono avere:



1. Protezione contro sovracorrenti e cortocircuiti; questa protezione si può ottenere tramite interruttore magnetotermico o con fusibili; questi devono essere tarati sulla corrente d'impiego del motore.



2. Protezione contro i sovraccarichi, tramite relè termico che controlla un teleruttore di potenza a monte del motore.
3. Protezione contro la sovravelocità, ad esempio nel caso in cui il carico meccanico possa trascinare il motore e questa possa diventare una condizione di pericolo.
4. Protezione, se particolari condizioni di funzionamento in sincronia con altre macchine o parti di macchine lo richiedono, contro l'interruzione della tensione di alimentazione o la riduzione della stessa tramite relè di minima tensione che controlla un interruttore automatico di potenza sezionatore



Protezioni termiche interne: (secondo CEI 2-3 / IEC 34-1)

Le protezioni elettriche presenti sulla linea di alimentazione del motore possono essere insufficienti ad assicurare la protezione dai sovraccarichi. Infatti, se peggiorano le condizioni di ventilazione, il motore si surriscalda ma le condizioni elettriche non si modificano e ciò inibisce le protezioni sulla linea. Si ovvia a questo inconveniente installando intimamente protezioni sugli avvolgimenti:



dispositivo bimetallico PTO

è un dispositivo elettromeccanico che, normalmente chiuso, una volta raggiunta la temperatura di scatto si apre elettricamente; si ripristina automaticamente quando la temperatura scende sotto il limite di scatto.

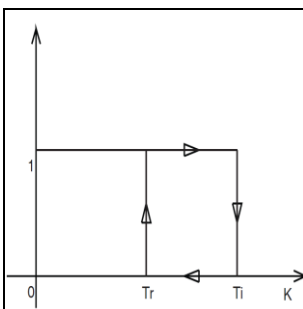

Tr= opening temperature (il motore si ferma)

Ti= re-closing temperature (il motore torna a funzionare)

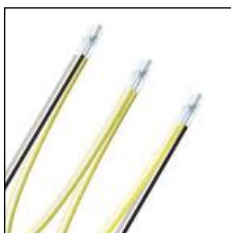

dispositivo termistore PTC

questo dispositivo varia la sua resistenza in modo repentino e positivo una volta raggiunta la temperatura di intervento. I motori dalla taglia 160 alla taglia 355L sono equipaggiati di serie con 3 termistori PTC immersi nell'avvolgimento, con temperatura di intervento di 130°C nei motori in classe F (serie standard DELPHI) o 160°C nei motori in classe H+ (serie DELFIRE).

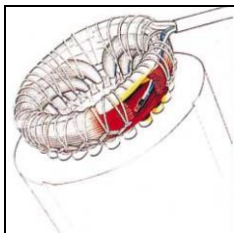

posizione PTC

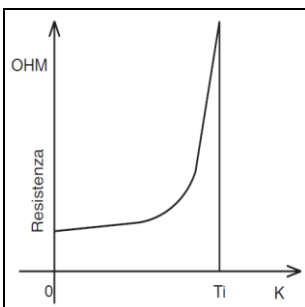

T_i = temperatura di intervento

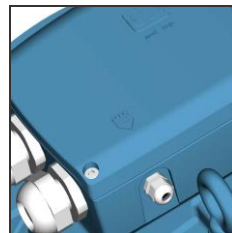

grandezza 160-400
pressacavo per PTC



dispositivo PT100

è un dispositivo che varia con continuità, e in modo crescente, la sua resistenza in funzione della temperatura. Si presta al rilievo continuo di temperatura degli avvolgimenti tramite apparecchiature elettroniche.

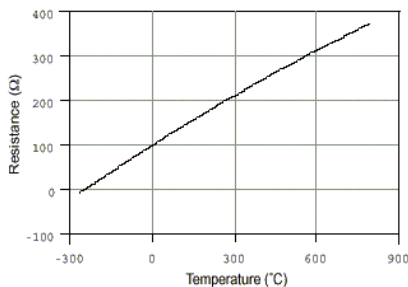

Nel rispetto della norma IEC34-1 tutti i motori possono sopportare sovraccarichi di 1,5 volte la corrente nominale per 2 minuti e 1,6 volte la coppia nominale per 15 secondi (V e Hz nominali)



SCHEDAPT - Modulo di controllo sonde termiche motore

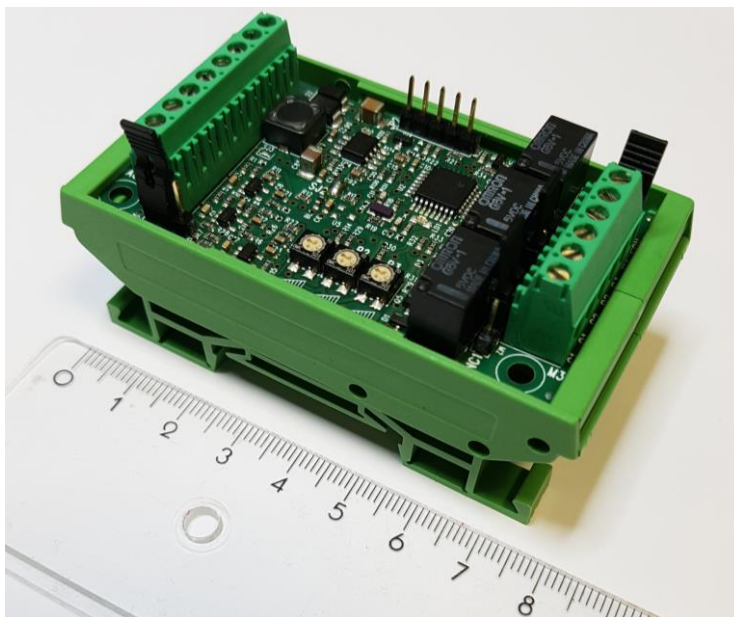

https://www.motive.it/upload/documenti/manuali/SCHEDAPT_ita.pdf





Electrical and thermal protections

protections must be chosen based on the specific running conditions, according to standards EN 60204-1 (for ATEX motors, see also EN60079-14 and EN61241-14).

External protections

It is possible to have:



1. Protection against overcurrent and short-circuits. this protection can be obtained through the magnetothermal circuit breaker or with fuses; these must be calibrated on the motor current.



2. Protection against overload by thermal relay that controls a power line contactor upstream the motor.
3. If the application requires, protection against excessive speed of the electric motor, for example if the mechanical load may drive the electric motor itself and thereby create a hazardous situation.
4. If special conditions or synchronised operation with other machines or parts of machines require it, protection against power failures or dips by means of a minimum voltage relay that controls an automatic power knife switch.



Inner thermal overload cut-out switches (per CEI 2-3/IEC 34-1)

The electrical protections on the motor power line may not be sufficient to protect against overloads. If the cooling conditions worsen, the motor overheats but the electrical conditions do not change, which inhibits line protections. Installing built-in protections on the windings solves this problem:



bimetallic device “PTO”

this is a normally-closed electromechanical device that opens when the threshold temperature is reached; it automatically resets when the temperature falls below the threshold level. Bimetallic devices are available with various intervention temperatures and without automatic reset, per EN 60204-1.

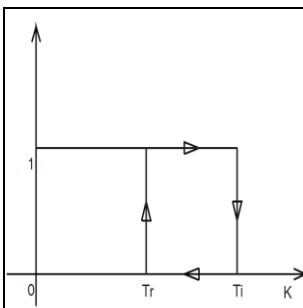

Tr= Opening temperature (motor stops)

Ti= Re-closing temperature (motor works again)

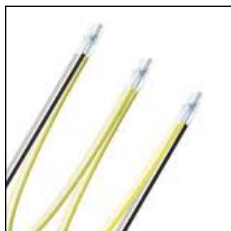

PTC thermistor device

this device promptly, positively adjusts its resistance once the threshold temperature is reached. Motors from size 160 to size 355L are equipped as standard with 3 PTC thermistors immersed in the winding, with activating temperature of 130°C in class F motors (standard DELPHI series) or 160°C in class H+ motors (DELFIRE series).

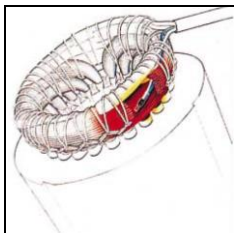

PTC position

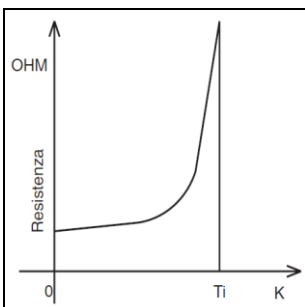

Ti= activating temperature



Size 160-400
PTC cable gland



PT100 device

this is a device that continuously, increasingly adjusts its resistance according to the temperature. It is useful for constant measuring of the winding temperatures using electronic

In compliance with IEC34-1, all motors can be exposed to overload conditions of 1,5 times the rated current for 2 min and 1,6 times the rated torque for 15 sec (at rated V and Hz)

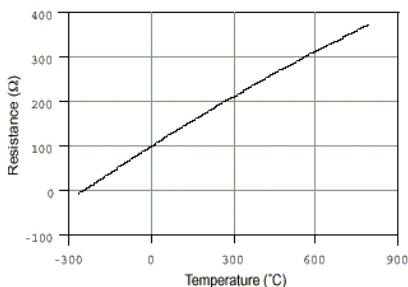

According to IEC34-1 norm, all motors withstand a temporary overload of 1.5 times the rated current for 2 minutes, and 1.6 times the rated torque for 15 seconds (at rated V and Hz)



SCHEDAPT - Motor thermal probes control card

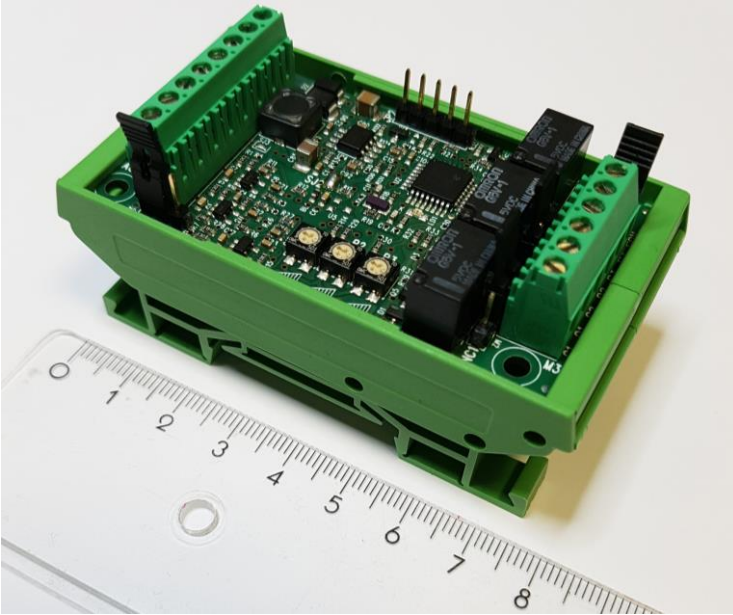

https://www.motive.it/upload/documenti/manuali/SCHEDAPT_eng.pdf

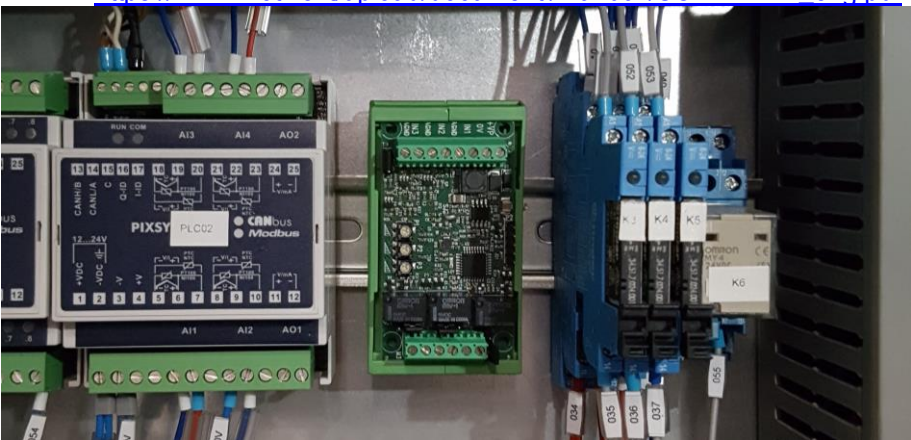



collegamento elettrico

Le operazioni di collegamento alla rete elettrica (valide anche per circuiti ausiliari) devono essere effettuate in ottemperanza alle seguenti prescrizioni:

- qualunque operazione sull'impianto deve essere effettuata da personale addestrato;
- il motore deve essere disattivato ed isolato;
- assicurarsi che non sia possibile un riavvio accidentale;
- accertarsi dell'assenza di tensione;
- dove la rete non sopporta la corrente d'inserimento diretto, il motore può essere avviato mediante un commutatore stella-triangolo. Ciò può avvenire soltanto nei motori il cui collegamento degli avvolgimenti per la tensione nominale è triangolo.
- l'allacciamento deve essere effettuato in modo tale da garantire un collegamento elettrico duraturo e sicuro;
- assicurare il corretto dimensionamento dei cavi di alimentazione
- assicurarsi che nella scatola collegamenti non siano presenti né corpi estranei, né sporcizia o umidità. Ricontrollare la chiusura di tutti i pressacavi e tappi utilizzati e non serrare bene il coperchio della scatola coprimorsettiera per prevenire la penetrazione di polvere ed acqua;
- nel caso di motori dotati di freno (serie AT..), verificare il corretto funzionamento del freno prima della messa in servizio;
- il cambio del senso di rotazione si può ottenere intercambiando le due fasi.

electrical connection

The operations for the connection to the electric network (valid for auxiliary circuits, too) must be performed in compliance with the following indications:

- any operation on the plant must be run by trained personnel;
- the motor must be disabled and isolated;
- make sure that a casual start can not occur;
- make sure that there is no voltage;
- If the network does not sustain the direct input voltage, the motor can be started by means of a star/delta commutator, which is possible only in motors where the connection of the winding for rated voltage is delta.
- the electric connection must be made in order to be long-lasting and safe;
- assure correct dimensioning of power supply cables
- make sure that in the box for the connection there is neither foreign bodies, nor dirty/humid parts. Recheck the proper closure of all used and unused cable glands and caps and tight terminal box lid in order to prevent the entrance of dust and water;
- when testing without output components secure the keyway;
- in motors with brake (AT.. series), please verify the brake switching before the starting process;
- you can change to counter-rotation by interchanging the two phases.



Schemi di collegamento (DELPHI 3PH)

Motore tipo	56	63-100	112	132	160-180	200-225	250-355	400
pressacavo	M16	M20	M25	M32	2xM40	2xM50	2xM63	3xM63
diam cavi mm	3-7	10-14	9-16	13-20	20-26	25-31	29-35	29-35



Cod. Motive cavo	descrizione cavo	Corrente motore In [A]
CAVOFG16OR4G1.5MT	FG16OR 4G1,5 mm ²	0 ÷ 10
CAVOFG16OR4G2.5MT	FG16OR 4G2,5 mm ²	11 ÷ 16
CAVOFG16OR4G4MT	FG16OR 4G4 mm ²	17 ÷ 22
CAVOFG16OR4G6MT	FG16OR 4G6 mm ²	23 ÷ 32
CAVOFG16OR4G10MT	FG16OR 4G10 mm ²	33 ÷ 50
CAVOFG16OR4G16MT	FG16OR 4G16 mm ²	51 ÷ 64
CAVOFG16OR4G25MT	FG16OR 4G25 mm ²	65 ÷ 90
CAVOFG16OR4G35MT	FG16OR 4G35 mm ²	91 ÷ 110
CAVOFG16OR4G50MT	FG16OR 4G50 mm ²	111 ÷ 130
CAVOFG16OR4G70MT	FG16OR 4G70 mm ²	131 ÷ 170
CAVOFG16OR4G95MT	FG16OR 4G95 mm ²	171 ÷ 200
CAVOFG16OR4G120MT	FG16OR 4G120 mm ²	201 ÷ 240
CAVOFG16OR4G150MT	FG16OR 4G150 mm ²	241 ÷ 270



CAVOFG16OR4G185MT	FG16OR 4G185 mm ²	271 ÷ 305

Il collegamento dei cavi d'alimentazione alla morsetteria deve essere eseguito capocorda su capocorda

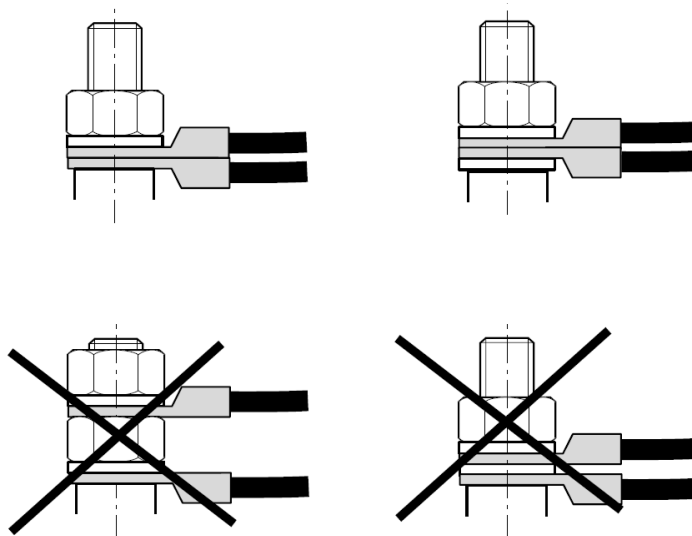

Coppia di serraggio (N.m) sui dadi delle morsettiere:

 Nm	M4	M5	M6	M8	M10	M12	M16
steel	2	3,2	5	10	20	35	65
brass	1	2	3	6	12	20	50



Gli avvolgimenti dei motori trifase serie Delphi possono essere collegati a stella o a triangolo.

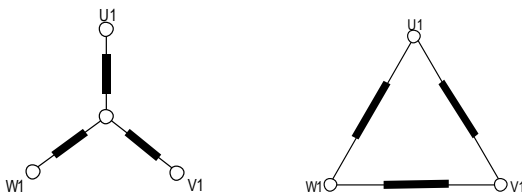

Collegamento a stella

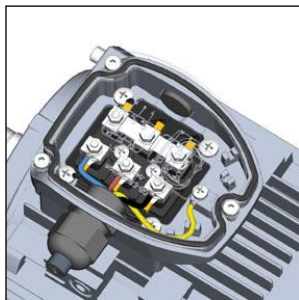

Il collegamento a stella si ottiene collegando insieme i terminali W2, U2, V2 e alimentando i terminali U1, V1, W1.

Collegamento a triangolo

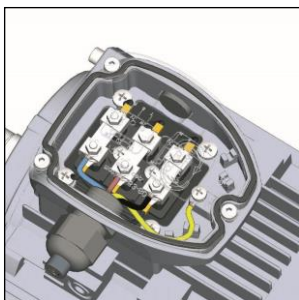

Il collegamento a triangolo si ottiene collegando la fine di una fase all'inizio della fase successiva.

Per gli schemi di collegamento dei motori autofrenanti, vedi il capitolo “serie Delphi AT...”.



Wiring Diagrams (DELPHI 3PH)

Motor type	56	63-100	112	132	160-180	200-225	250-355	400
Cable gland	M16	M20	M25	M32	2xM40	2xM50	2xM63	3xM63
Cables diam mm	3-7	10-14	9-16	13-20	20-26	25-31	29-35	29-35

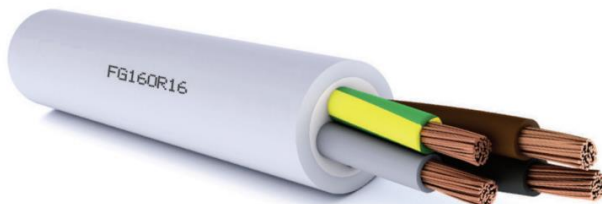

Motive code	Cable description	Motor current In [A]
CAVOFG16OR4G1.5MT	FG16OR 4G1,5 mm ²	0 ÷ 10
CAVOFG16OR4G2.5MT	FG16OR 4G2,5 mm ²	11 ÷ 16
CAVOFG16OR4G4MT	FG16OR 4G4 mm ²	17 ÷ 22
CAVOFG16OR4G6MT	FG16OR 4G6 mm ²	23 ÷ 32
CAVOFG16OR4G10MT	FG16OR 4G10 mm ²	33 ÷ 50
CAVOFG16OR4G16MT	FG16OR 4G16 mm ²	51 ÷ 64
CAVOFG16OR4G25MT	FG16OR 4G25 mm ²	65 ÷ 90
CAVOFG16OR4G35MT	FG16OR 4G35 mm ²	91 ÷ 110
CAVOFG16OR4G50MT	FG16OR 4G50 mm ²	111 ÷ 130
CAVOFG16OR4G70MT	FG16OR 4G70 mm ²	131 ÷ 170
CAVOFG16OR4G95MT	FG16OR 4G95 mm ²	171 ÷ 200
CAVOFG16OR4G120MT	FG16OR 4G120 mm ²	201 ÷ 240



CAVOFG16OR4G150MT	FG16OR 4G150 mm ²	241 ÷ 270
CAVOFG16OR4G185MT	FG16OR 4G185 mm ²	271 ÷ 305

Correct and wrong connection of the power cables terminal lugs to the terminal block:

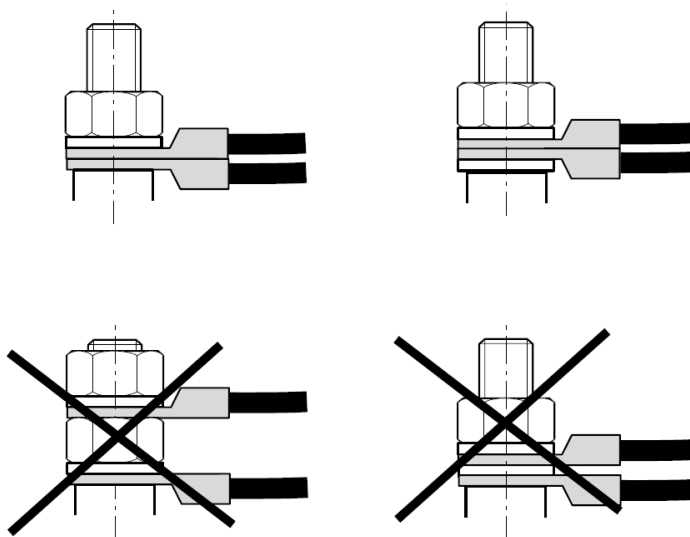

Torque (Nm) on the terminal block nuts

 Nm	M4	M5	M6	M8	M10	M12	M16
steel	2	3,2	5	10	20	35	65
brass	1	2	3	6	12	20	50



Delphi series three phase motors can be connected “Star” or “Delta” .

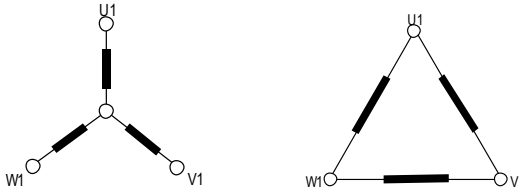

Star connection

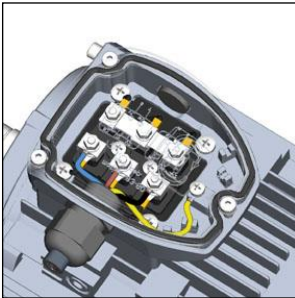

Star connection is obtained by connecting together the terminals W2, U2, V2 and supplying the terminals U1, V1, W1.

Delta connection

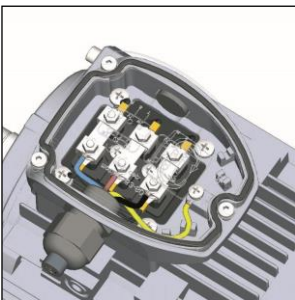

Delta connection is obtained by connecting the end of a phase with the beginning of the following one.

For brake motors wiring diagrams, see “AT.. Delphi series” chapter



**Double polarity motor
single winding (Dahlander)
2/4 – 4/8 Poles**

**Motore doppia polarità
singolo avvolgimento (Dahlander)
2/4 – 4/8 Poli**

High-speed connection **400 YY**
Connessione alta velocità **400 YY**

Low-speed connection **400 Δ**
Connessione basa velocità **400 Δ**

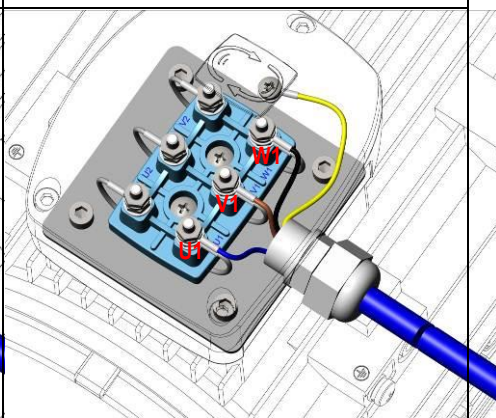
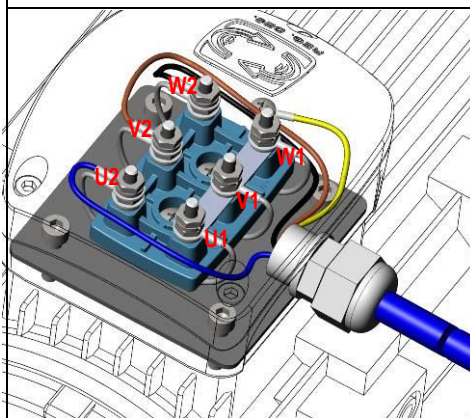
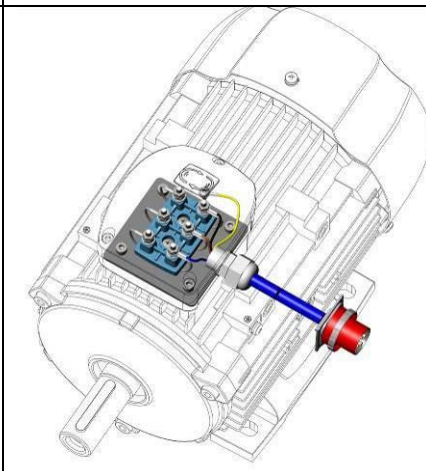
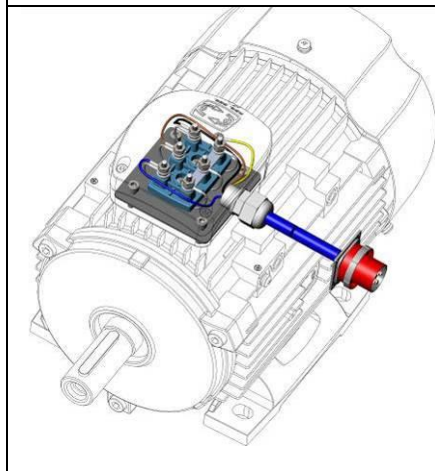

To use the 2 speeds, you must adopt a 6+1 wires cable and connect an external switch

Per sfruttare entrambe le velocità, adottare un cavo a 6+1 fili e collegare un commutatore esterno

Double polarity motor



with double winding
2/6 – 2/8 – 4/6 – 6/8 Poles

Motore doppia polarità
a doppio avvolgimento
2/6 – 2/8 – 4/6 – 6/8 Poli

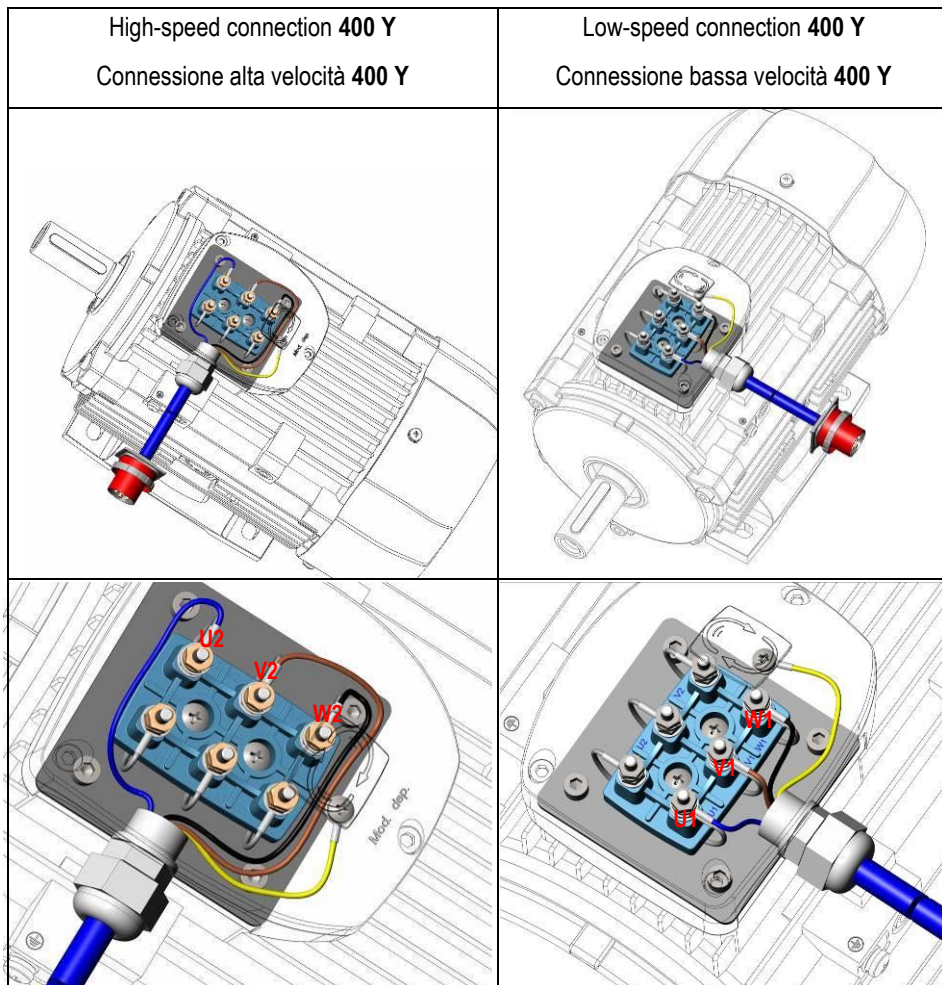

To use the 2 speeds, you must adopt a 6+1 wires cable and connect an external switch

Per sfruttare entrambe le velocità, adottare un cavo a 6+1 fili e collegare un commutatore esterno



Single phase motors MONO

Motori monofase MONO

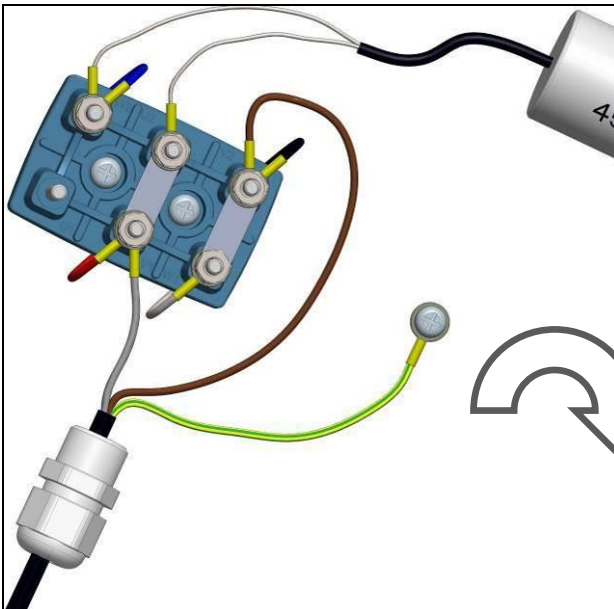
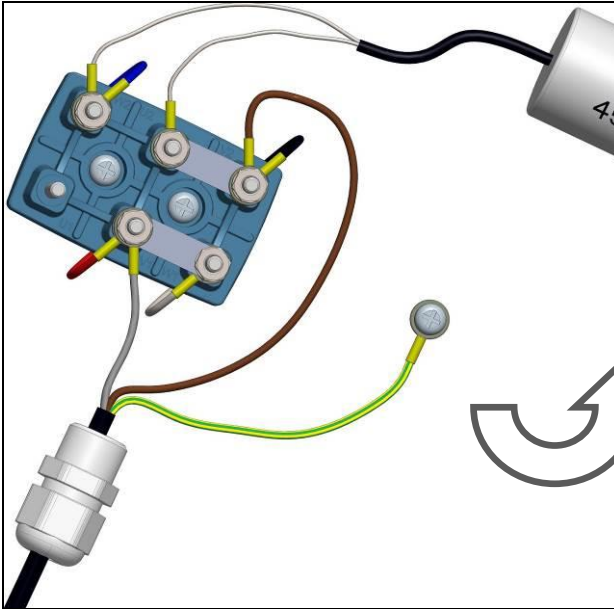



Starting Capacitor 3 wires MONO

Condensatore di spunto a 3 fili MONO

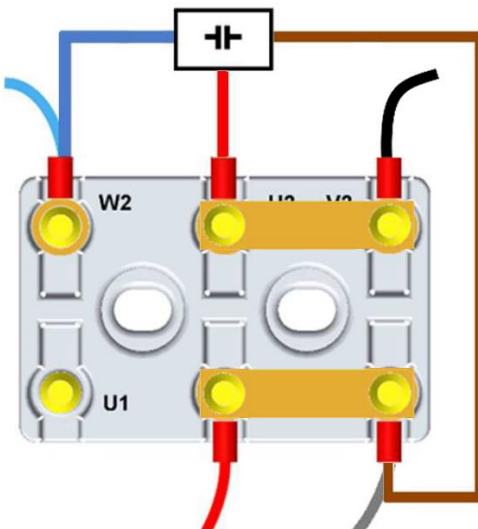
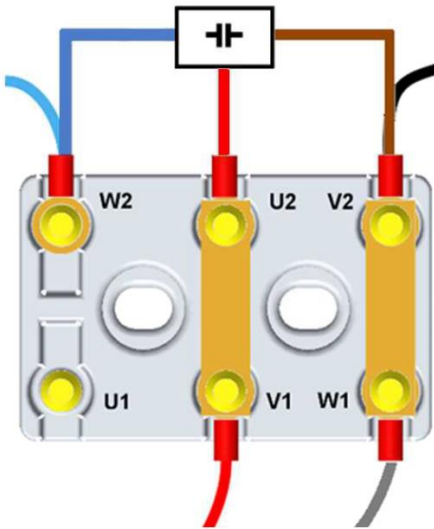

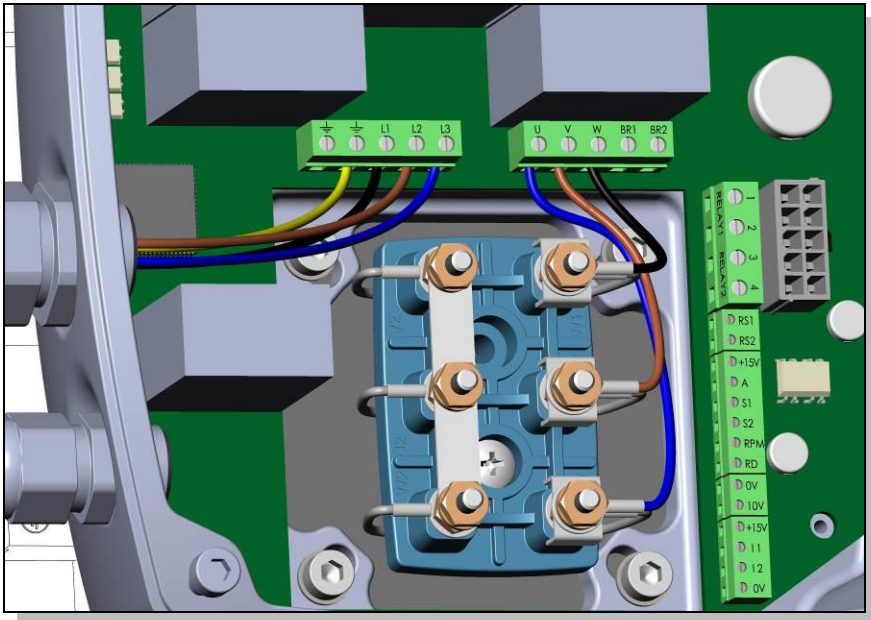
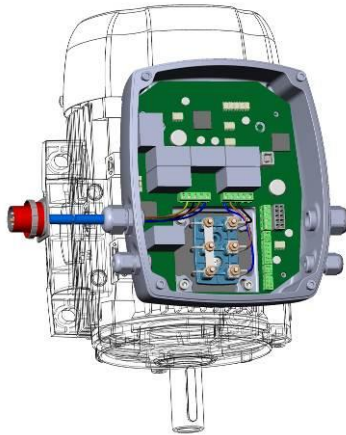
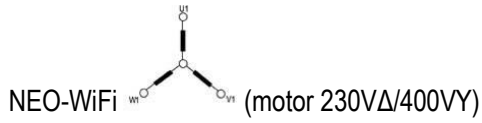

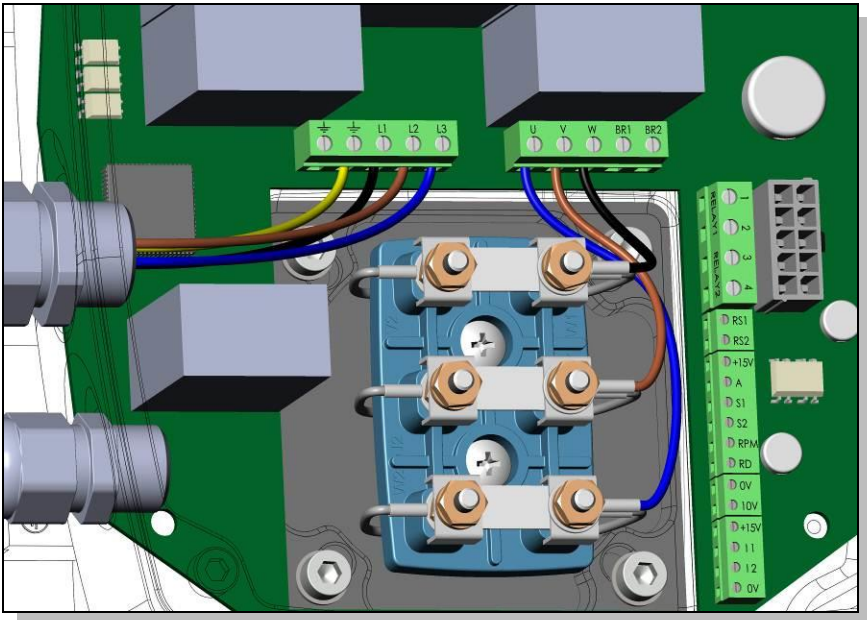
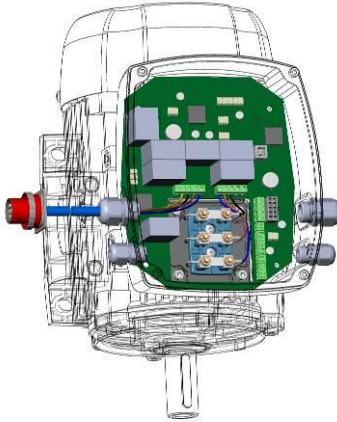
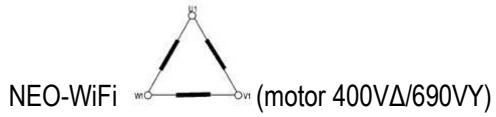



Messa in servizio

Prima dell'avviamento del motore effettuare un controllo generale, assicurandosi di aver rispettato tutte le procedure di installazione. In particolare modo verificare:

- che la tensione di alimentazione del motore corrisponda a quella prevista in targa;
- controllare il raccordo della piastrina di collegamento, serrare tutti i suoi dadi e fissare il coperchio della morsettiera avendo cura di non danneggiare la guarnizione;
- verificare la libera rotazione dell'albero manualmente;
- controllare se tutte le fasi hanno tensione e, possibilmente, misurare che il loro valore sia conforme al valore nominale di targa.

Start

Before starting make an overall check of the motor to make sure that all the indications about installation have been applied. In particular

- make sure that the voltage of the motor is equivalent to the one expected (see motor plate) and
- check the union of the connecting link, close all its dies and secure the cover of the terminal board without damaging the gasket;
- verify the free rotation of the motor shaft manually;
- check if there is voltage in all the phases and eventually measure their value to check their conformity to the plate values.

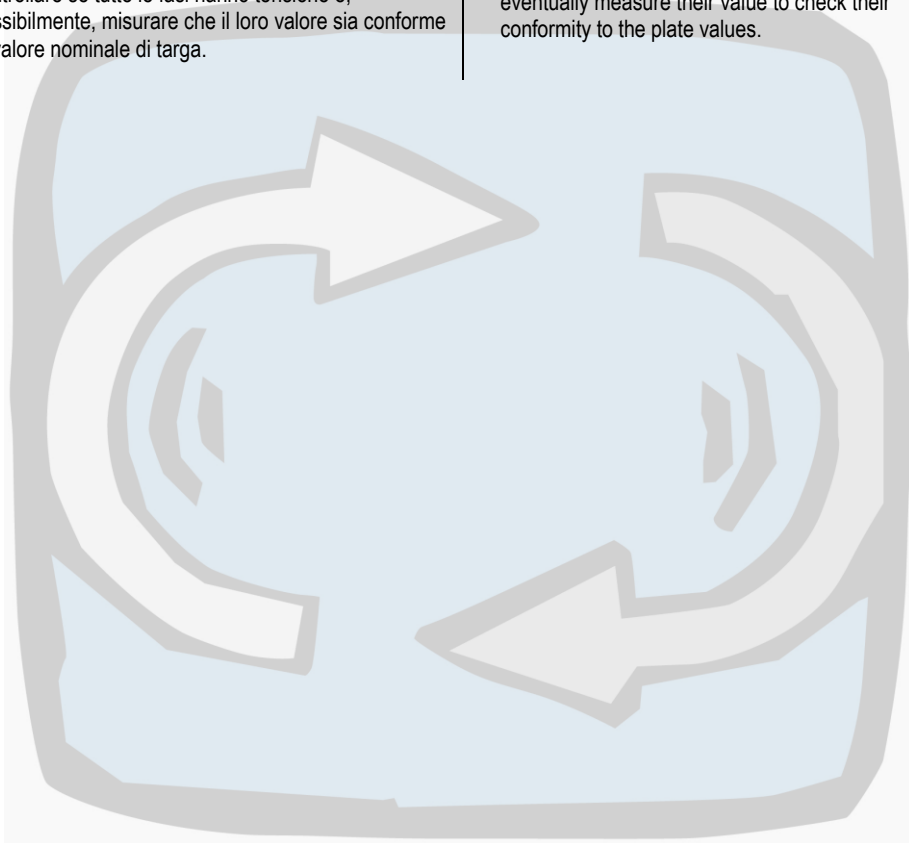



Rain shield

For outdoor applications with V5 – V18 – V1 – V15 installation (shaft down), we recommend to mount a rain shield. This configuration may also be used in textiles processing industry.

The rain shield is compulsory in ATEX motors with mounting V5 – V18 – V1 – V15

Tettuccio parapioggia

Per applicazioni all'aperto con montaggio in posizione V5 – V18 – V1 – V15 (albero in basso) è consigliabile montare un tettuccio parapioggia. Questa esecuzione si può utilizzare anche in ambienti per lavorazioni tessili

Il tettuccio para-pioggia è obbligatorio nei motori atex, quando gli stessi vengono montati in posizione V5 – V18 – V1 – V15

Type	L
63	215
71	323
80	369
90S	403
90L	428
100	469
112	453
132S	573
132M	613
160M	770
160L	825
180M	915
180L	955
200L	1025
225S	1155
225M	1160
250M	1220
280S	1265
280M	1315
315S	1540
315M	1570
315L	1680
355M	1840
355L	1870

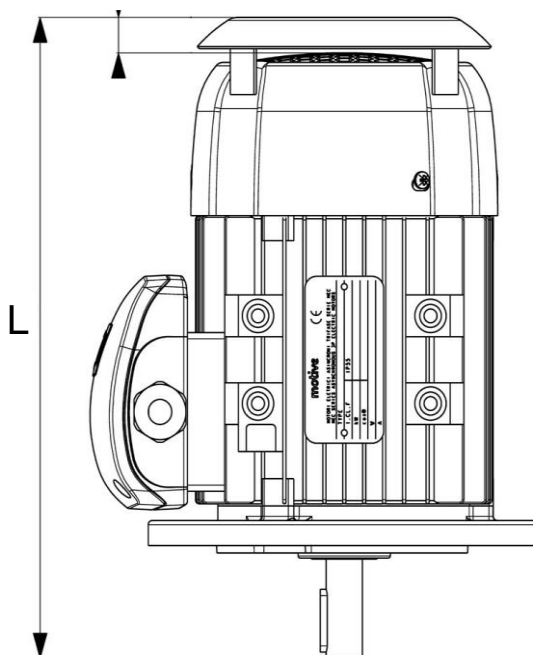



Serie Delphi AT..

I motori autofrenanti serie Delphi ATDC, AT24, ATTD e ATTD24 prevedono l'impiego di freni a pressione di molle alimentati in corrente continua, calettati saldamente su uno scudo in ghisa nella parte posteriore del motore. AT24 e ATTD24 sono dotati di freni a 24V per poter essere alimentati direttamente dalle separate uscite 24V di cui la maggior parte degli inverter sono dotati.

Si possono effettuare due tipi diversi di regolazione per i motori ATDC e AT24.

Regolazione del traferro S

Per un corretto funzionamento, il traferro S tra l'elettromagnete ⑦ e l'ancora mobile ① dev'essere compreso tra i seguenti valori:

Motore tipo	traferro S (mm)
63~71	0.20~0.30
80~100	0.40~0.50
112~280	0.50~0.60

La regolazione si effettua agendo sulle bussole filettate ⑩ controllando mediante spessore che si sia raggiunto il valore di traferro desiderato. Per i freni grandezza 63, 71, 80 e 90 la regolazione del traferro S non è modificabile.

Regolazione della coppia frenante

Si ottiene agendo sui grani di regolazione ⑨ presenti nei motori ATDC/ATTD taglie 112÷280 o con la manopola (11) dei freni AT24/ATTD24.

La coppia frenante è già regolata dalla motive sul valore massimo e si consiglia di non variarla.

AT.. Delphi series

Delphi ATDC, AT24, ATTD and ATTD24 series self-braking motors use one or 2 spring-pressure brakes, firmly spliced onto a cast iron shield at the back of the motor.

On AT24 and ATTD24, the 24Vdc single or double brakes are designed to be directly connected to an inverter (usually having a 24Vdc plug).

Two different types of adjustment are possible for motors ATDC and AT24

Air gap S adjustment

For proper operation, the air gap S between electromagnet ⑦ and the mobile armature ① must be between the following indicated limits:

Motor type	S air gap (mm)
63~71	0.20~0.30
80~100	0.40~0.50
112~280	0.50~0.60

The adjustment is made by using the threaded bushes ⑩, using a thickness gauge to make sure that the wished air gap is reached. For brakes size 63, 71, 80 and 90, the setting of the air gap S cannot be changed.

Braking torque adjustment

The braking torque can be increased by tightening the adjuster screws ⑨ of ATDC/ATTD motors size 112÷280, or by turning the knob (11) of AT24/ATTD24 brakes. The setting has already been made by motive at the max value, and therefore we suggest to not to intervene on it.

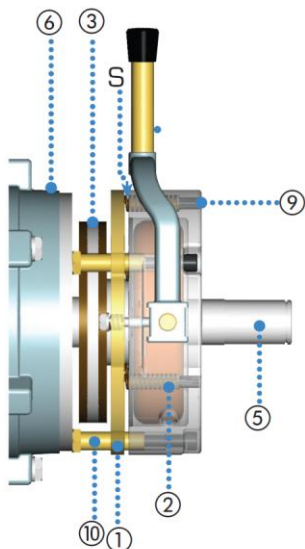

- ① Ancora mobile
- ② Molle
- ③ Disco freno (ferodo)
- ④ Trascinatore
- ⑤ Albero motore
- ⑥ Flangia motore
- ⑦ Bobina
- ⑧ Leva di sblocco
- ⑨ Grani di regolazione
- ⑩ Bussola filettata
- ⑪ manopola di regolazione coppia
- ⑫ piastra di connessione

S Traferro

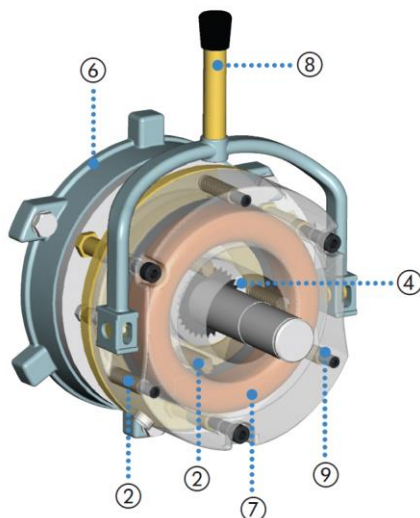

- ① Mobile armature
- ② springs
- ③ Brake disc
- ④ Driver
- ⑤ Motor shaft
- ⑥ Motor flange
- ⑦ Electromagnet
- ⑧ Release lever
- ⑨ Adjuster screws
- ⑩ Threaded bush
- ⑪ braking torque setting knob
- ⑫ ATTD connection plate

S Air gap

Nota: L'utilizzo del freno non è ammesso nei motori atti ad essere installati in ambienti con atmosfere esplosive (zona 2 - gas). Per ulteriori dettagli vedere l'"addendum ATEX".

Note: Brake motors are generally not admitted in ATEX motors. For further details, see the file "ATEX addendum"



AT10



AT24

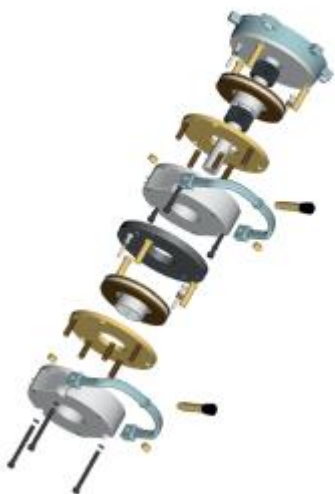
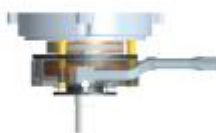

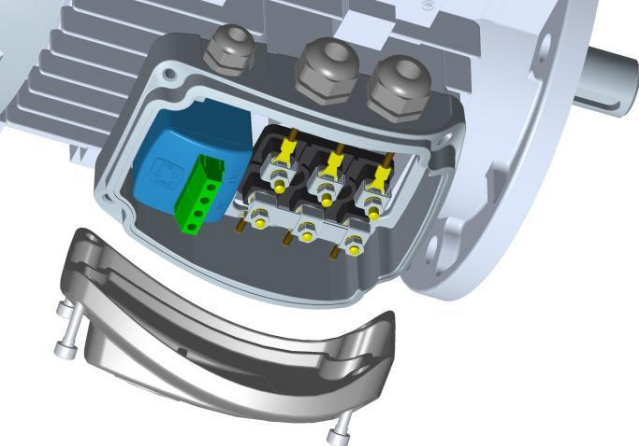

I freni Motive ATDC sono freni a corrente continua alimentati da un raddrizzatore di tensione installato nel coprimorsettiere.

Le prestazioni di velocità mSec, potenza W, ed il momento torcente Nm di tali freni, sono esposti nel sito www.motive.it.

La seguente tabella riporta le alimentazioni di raddrizzatore e freno nella serie ATDC

Type	Volt in entrata al raddrizzatore [Vac]	Volt da raddrizzatore a freno [Vdc]
ATDC 63-100	220-280	99-126
ATDC 112-280	380-480	171-216



I motori ATDC vengono forniti di serie con alimentazione freno separata. Nel caso di alimentazione da morsettiere motore, è previsto a corredo un kit completo di cavi e relative istruzioni di montaggio.

In nessun caso il raddrizzatore può essere alimentato da convertitore di frequenza / inverter / soft-start.

In caso di alimentazione del motore da inverter (fig. 5a e 5b), o con tensione speciale, o ad avviamento a tensione ridotta, o in presenza di carichi aventi un possibile movimento

inerziale, come i carichi sollevati (in questo caso allo spegnimento dell'alimentazione del motore, il carico può muovere il motore e farlo agire come generatore sul raddrizzatore del freno e quindi sul freno, evitandone il blocco) bisogna provvedere a scollegare tali ponticelli predisposti da motive ed alimentare separatamente il raddrizzatore (cap. "schemi di collegamento", fig. 5, 6, e 7).



Il raddrizzatore in versione TA risolve il problema del carico inerziale senza richiedere un'alimentazione separata del raddrizzatore (fig 3 and 4)

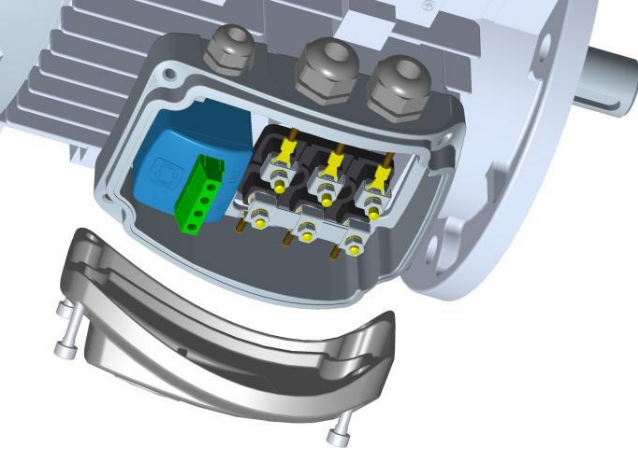

ATDC brakes are DC brakes power supplied by a rectifier installed inside the motor main terminal box.

The performance of all brakes, in terms of Watt, Nm and speed in mSec are shown in motive web-site www.motive.it .

The following table shows the voltages on the rectifier and the brake of ATDC model

Type	input voltage on rectifier [Vac]	output voltage to brake [Vdc]
ATDC 63-100	220-280	99-126
ATDC 112-280	380-480	171-216

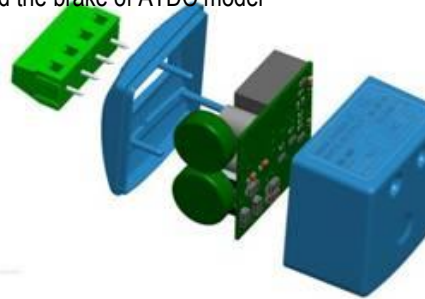

ATDC motors are supplied with separate brake power supply as standard. In the case of power supply from the motor terminal block, a complete kit of cables and associated assembly instructions is provided.

The rectifier cannot be power-supplied by frequency inverters or soft-start devices

In case that the motor is power supplied by a frequency inverter (fig. 5a and 5b), or at a special voltage*, or at a low tension during the start, or in case that the motor is used to move loads which can have an inertial movement, like lifted weights (such inertial movement can move the motor when the power is switched off, and the motor can act like a generator on the rectifier avoiding the brake locking), disconnect the motor main terminal board from the rectifier, and connect separately the rectifier (ATDC) (fig. 5a, 5b, 6 and 7).



TA special rectifier permits to solve the problem of inertial movements with no need for a separate power supply to the rectifier (fig 3 and 4)



ATDC 112-280  - 400Vac/180Vdc rectifier (fig.1)

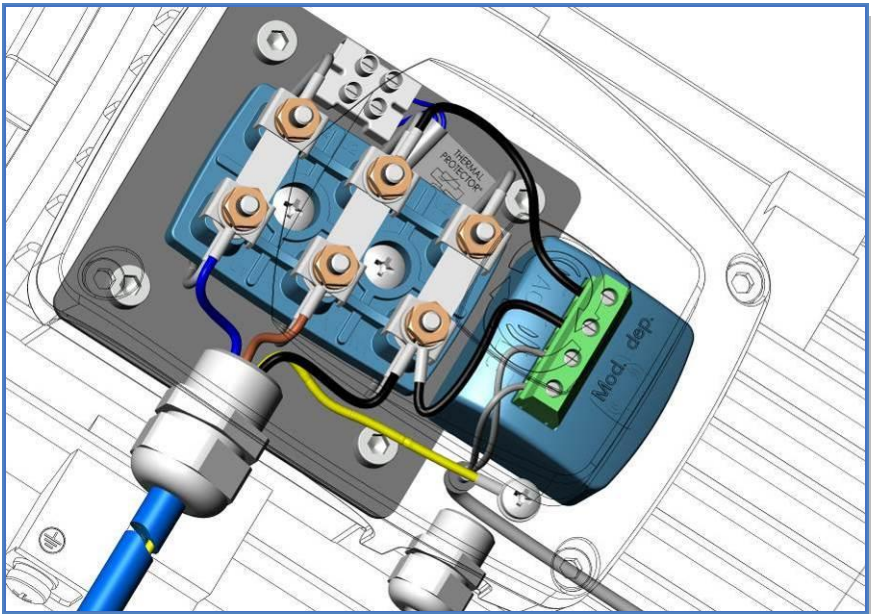
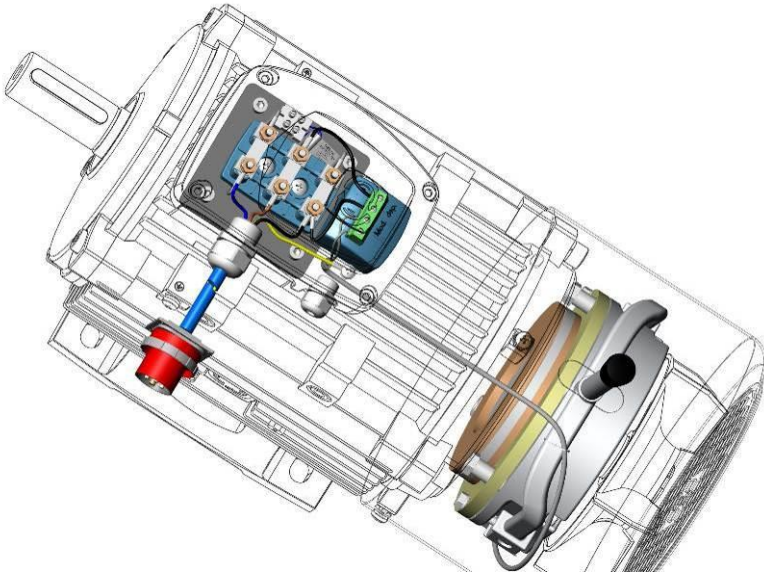



ATDC 63-100  - 230Vac/104Vdc rectifier (fig.2)

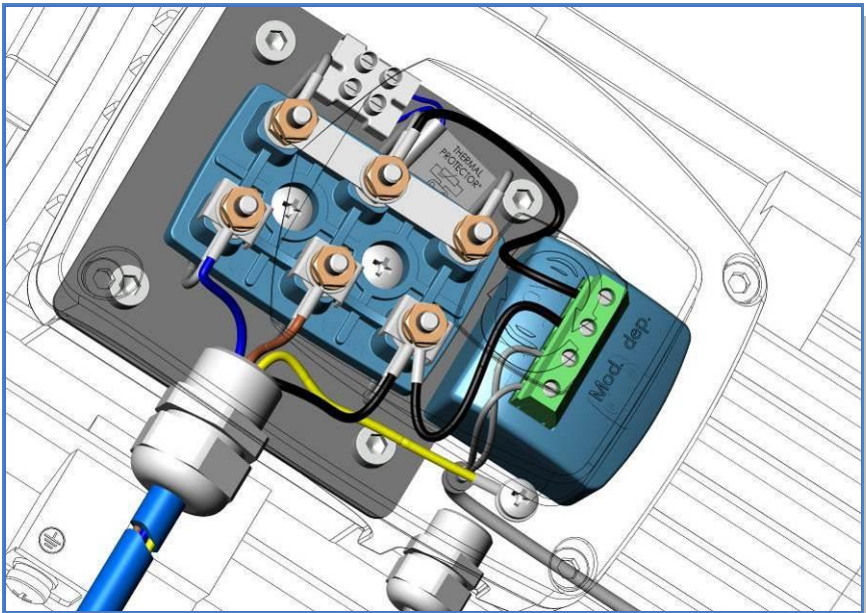
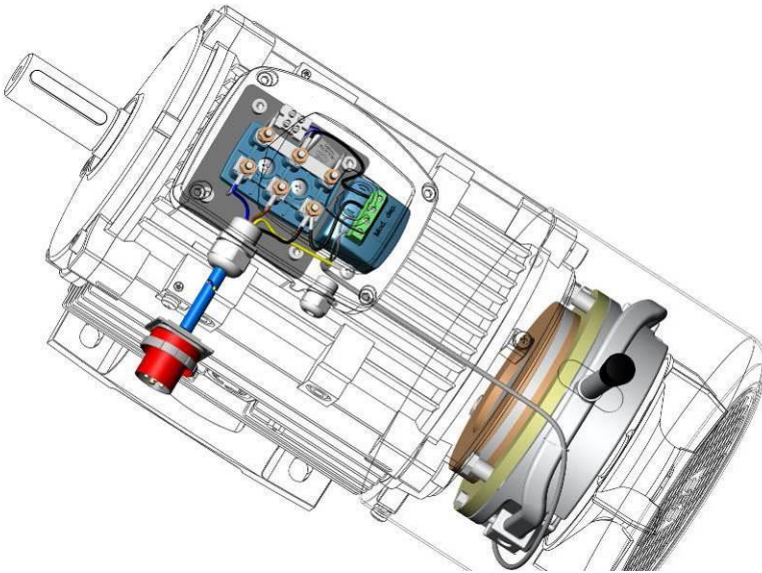



ATDC  400Vac/180Vdc TA rectifier (fig.3) **Not suitable if the motor is controlled by inverter*

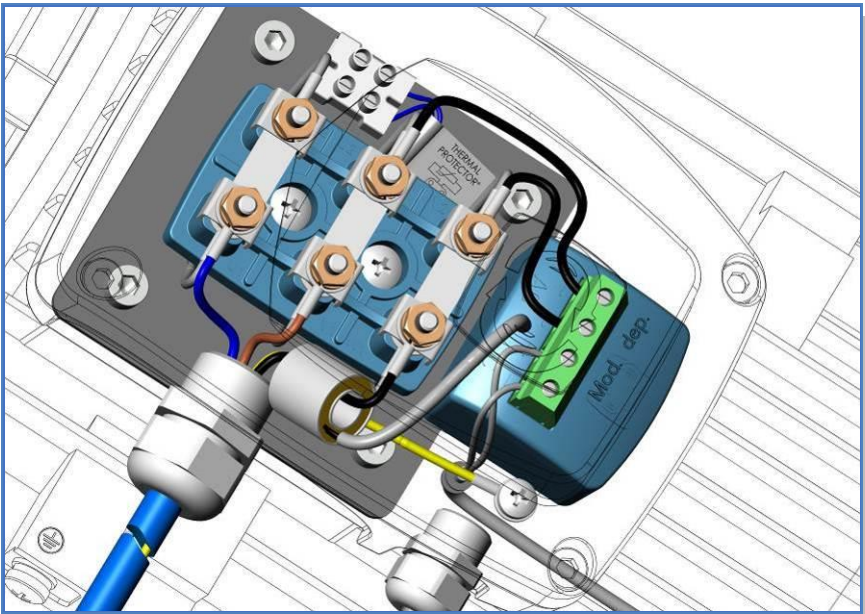
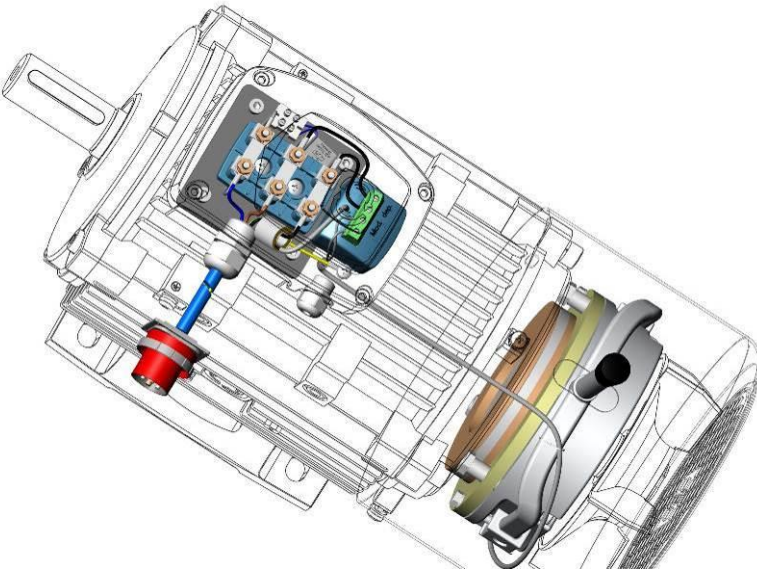



ATDC 112-280  (separate 400Vac/180Vdc rectifier) + inverter (fig. 5°)

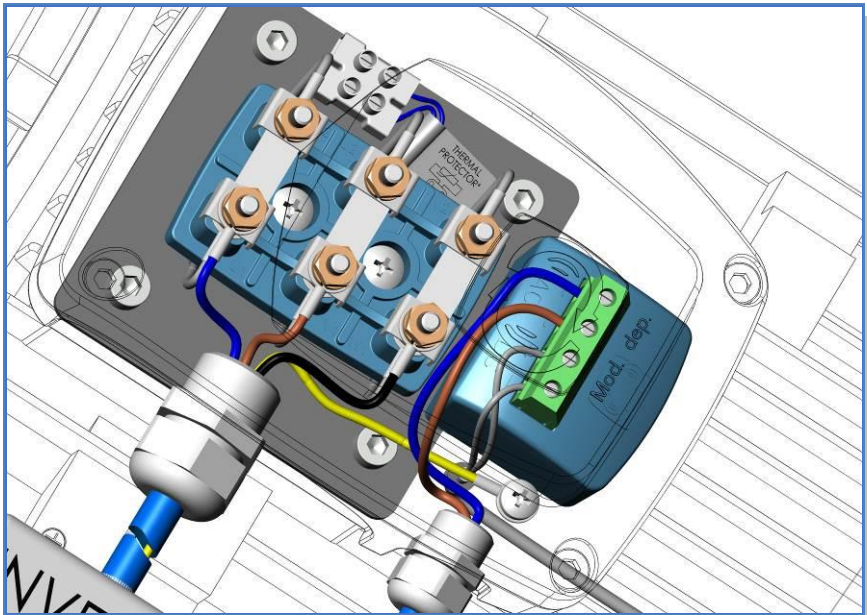
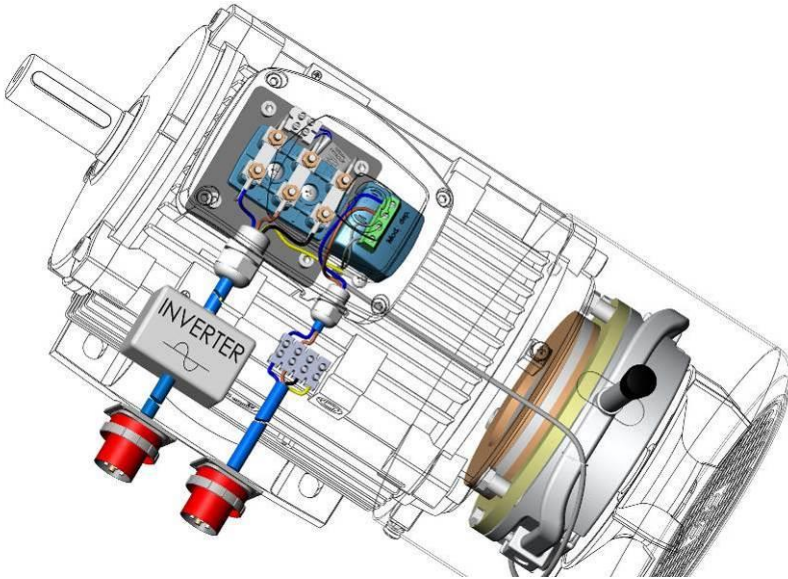



ATDC 63-100  (separate rectifier 230Vac/104Vdc) + inverter (fig. 5b)

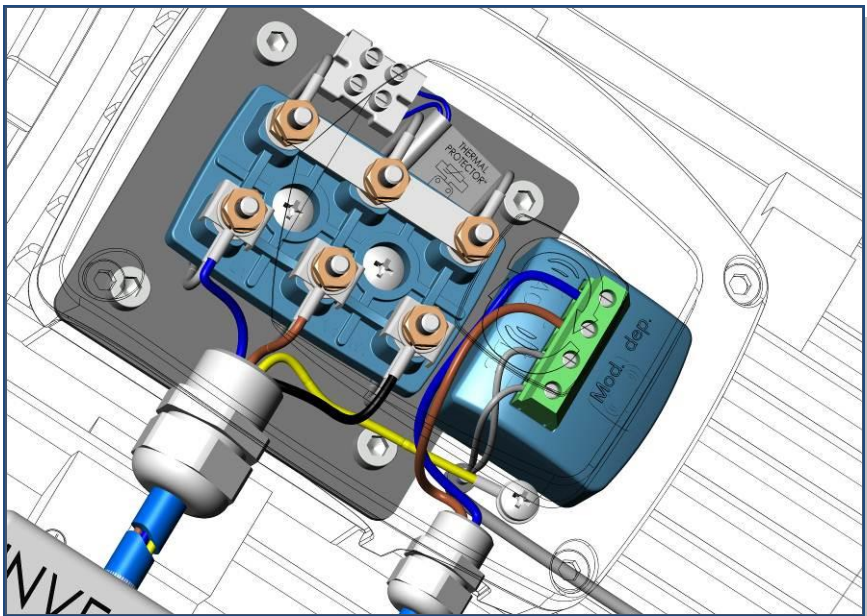
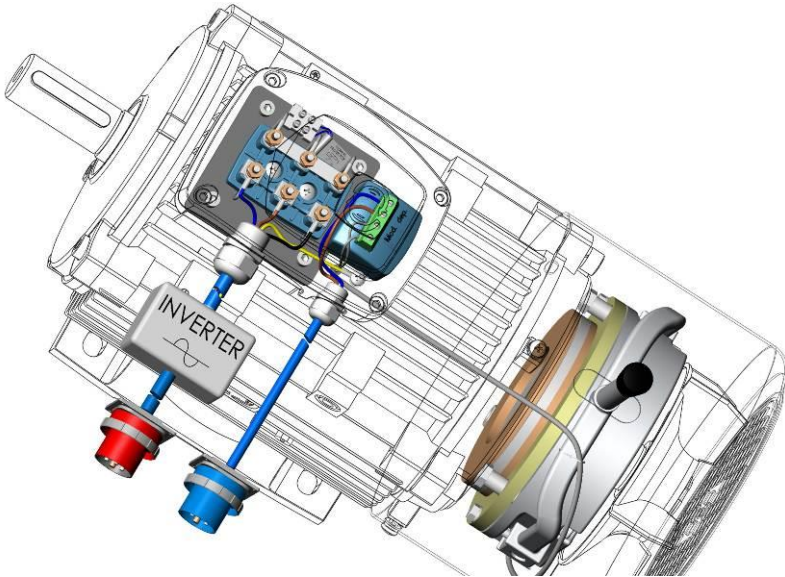



ATDC 112-280  + separate 400Vac/180Vdc rectifier connection (fig. 6)

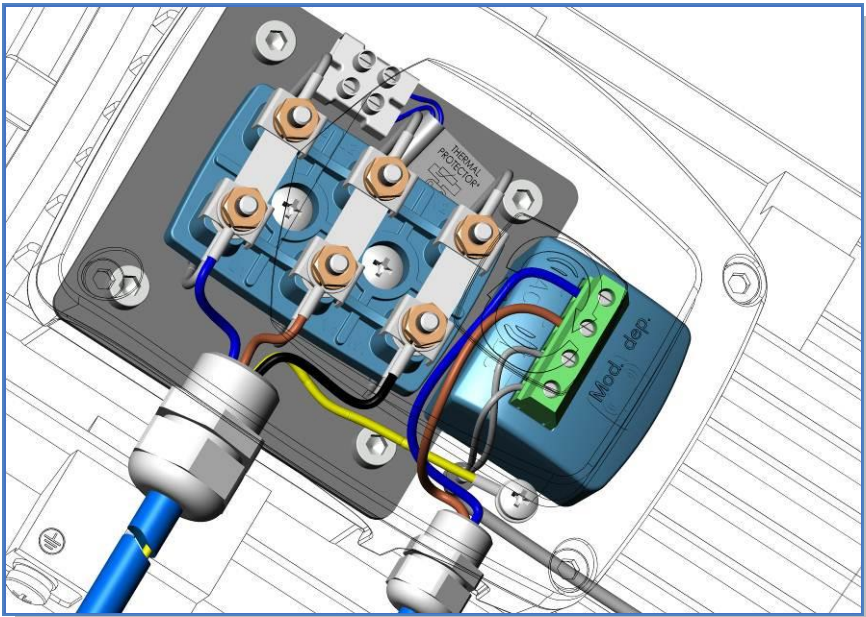
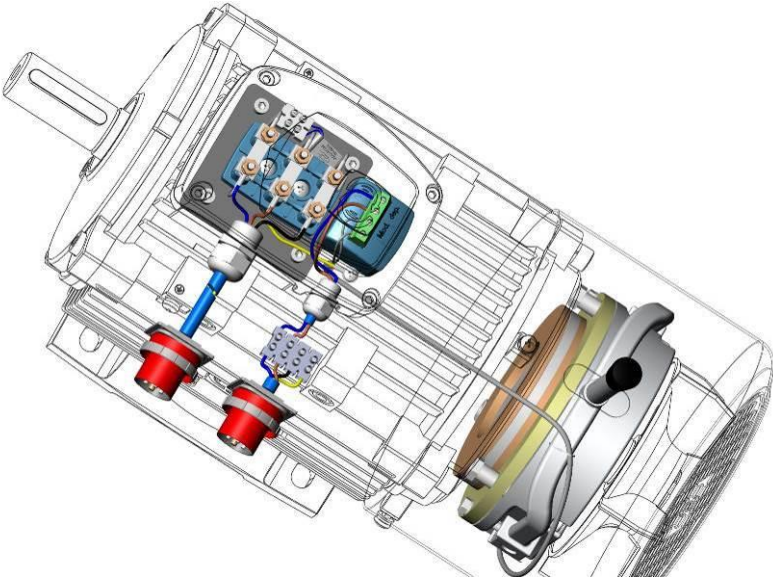



ATDC 63-100  + separate 230/104Vdc rectifier connection (fig. 7)

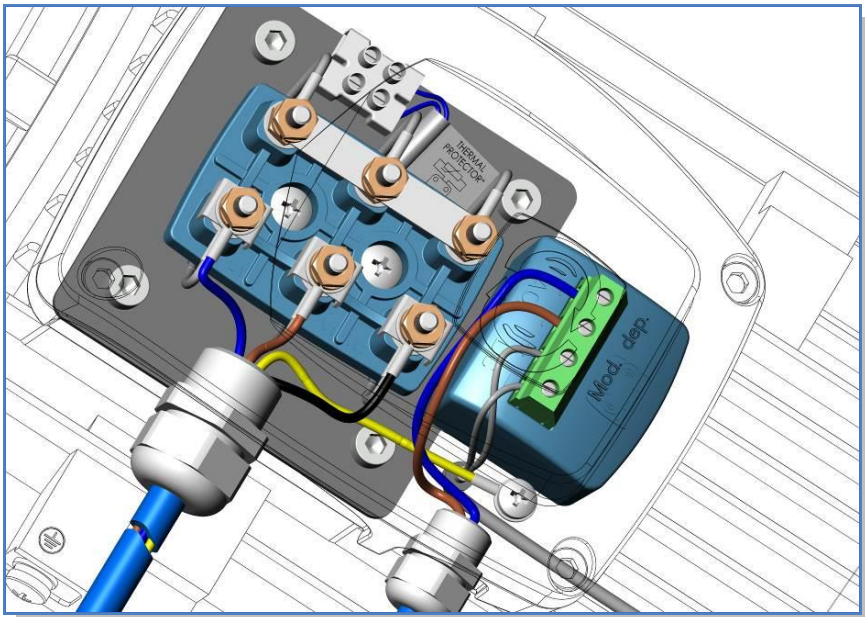
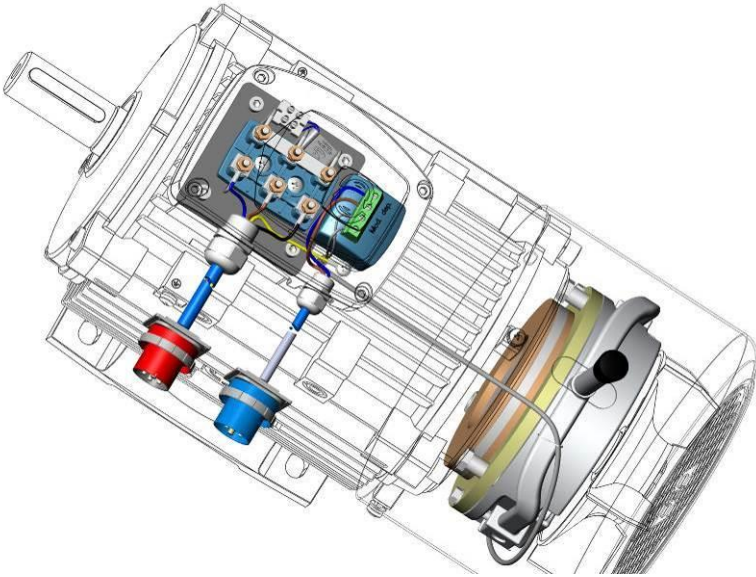



Sblocco

Manual release

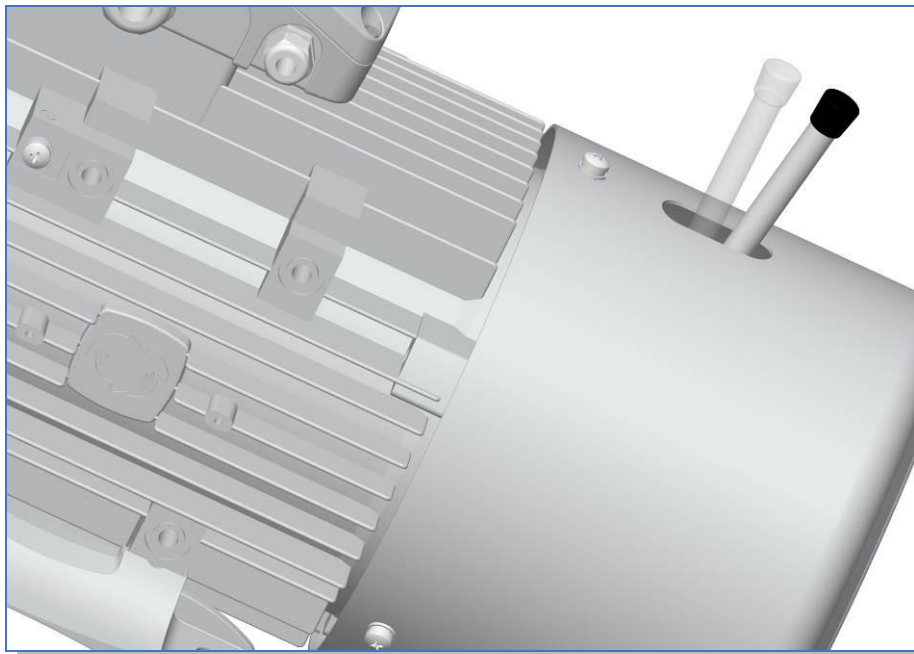

La leva di sblocco è di serie ma, se non desiderata, è come una vite e può essere smontata semplicemente girandola.

I motori con freno tandem ATTD e ATTD24 dalla taglia 180 alla taglia 280 non sono provvisti di leva di sblocco.

Motive brake motors are supplied with the manual release lever in their standard version. If not wished, the lever is like a screw, that can be taken away simply turning it

ATTD and ATTD24 tandem brake motors, from size 180 up to sized 280, cannot have the manual release



IP

I freni AT... sono IP55 da un punto di vista elettrico, ma meccanicamente, per un uso esterno (o per raggiungere un IP65), andrebbero protetti dalla ruggine e da effetti di incollatura del disco dovuti all'umidità. In tale caso si consiglia l'uso dei nostri anelli protettivi in gomma

Tale anello previene l'uscita o l'ingresso di polvere, umidità, sporco, fuori o dentro l'area di frenatura.

Esso viene montato inserendolo nell'apposita scanalatura predisposta sul freno. Se il freno non è provvisto di tale scanalatura, va ordinato un freno specificando la richiesta di tale requisito.

Per il mantenimento della coppia frenante nel tempo, è necessario svuotare periodicamente le parti interne all'anello dalla polvere generata dal ferodo del freno

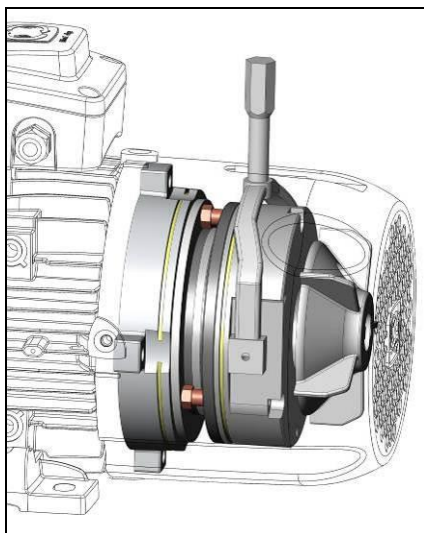

IP

AT.. brakes are IP55 under an electrical point of view, but mechanically, in case of an outdoor use (or to reach IP65), they should be protected by rust and by disc adhesion effects given by humidity. In such a case, we suggest to use our protective rubber ring seals

This device prevents the exit or ingress of dust, humidity, dirt, etc., out of or into the braking area.

It is inserted into the groove on the stator. If your brake doesn't have such a groove, you must order a specifically machined brake for that.

In order to safeguard the braking torque, it is necessary to clean periodically the parts inside the rubber ring seal by the dust created by the disc lining.

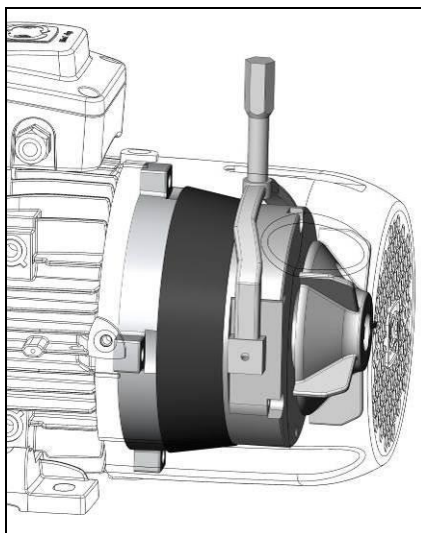



disco di contatto freno in inox

Su richiesta, laddove l'umidità presente nell'aria può comportare una precoce ossidazione della superficie di contatto tra disco freno e scudo in ghisa del motore, è possibile aggiungere una copertura in inox

stainless steel braking surface

When high humidity in the air can rust fastly the contact surface between the brake disc and the cast-iron NDE shield of the motor, you can request to motive to add a stainless steel shield

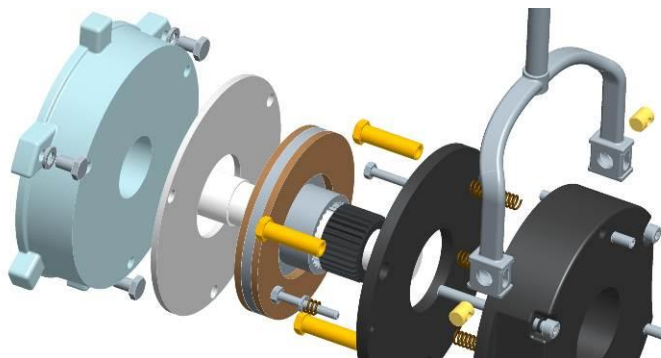

microinterruttori di rilevamento posizione freno

opzionali

micro-switches to detect brake position

Optional

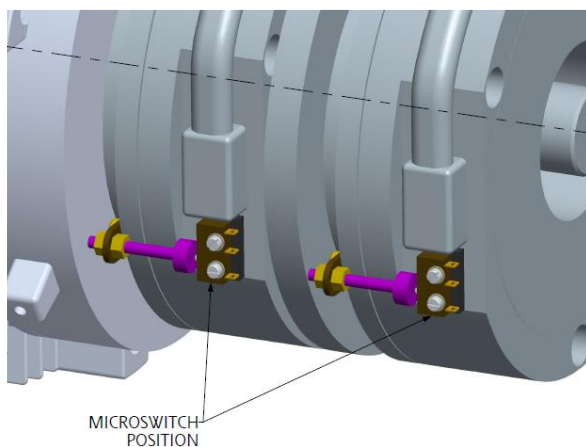



Conversione motore da standard ad autofrenante ATDC con “kit-ATDC/AT24”

From a standard motor to an ATDC brake motor thanks to “kit-ATDC/AT24”

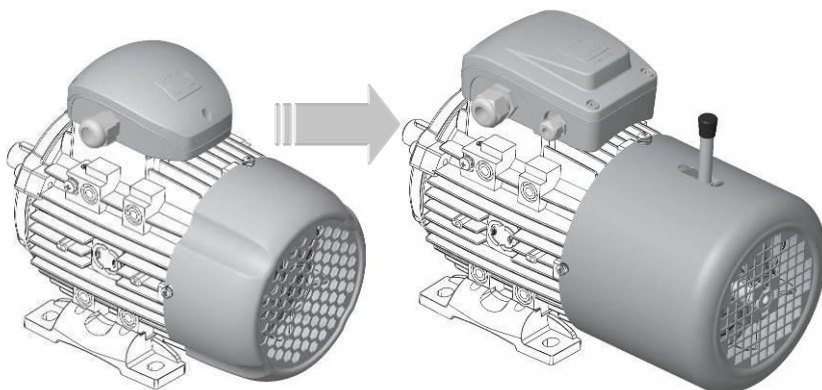

KIT-ATDC/AT24 (solo IEC90-112; 160)

KIT-ATDC/AT24 PARTS (IEC 90-112; 160 only)

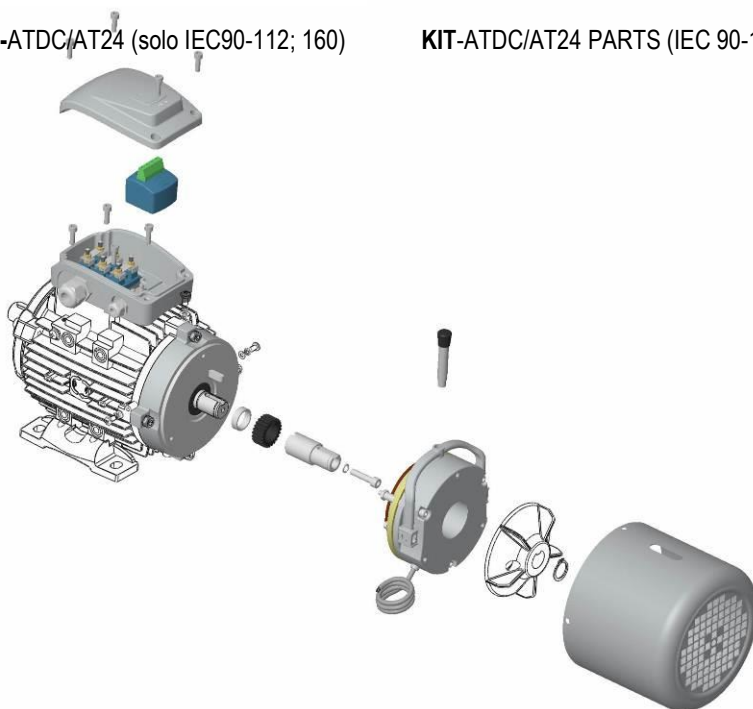



PASSI

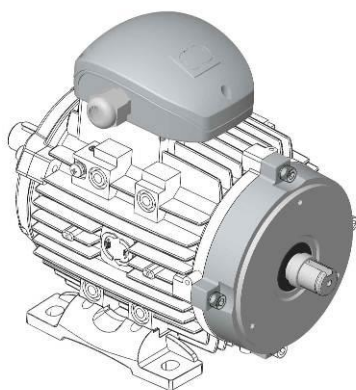
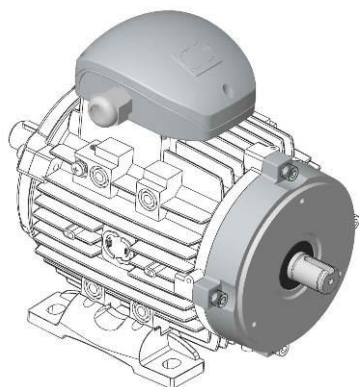
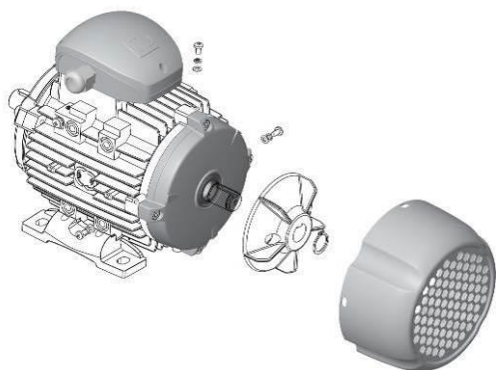

STEPS

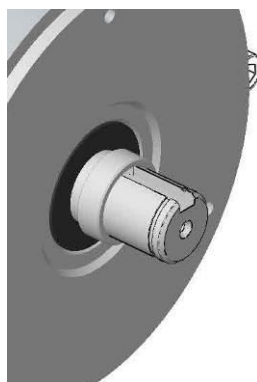
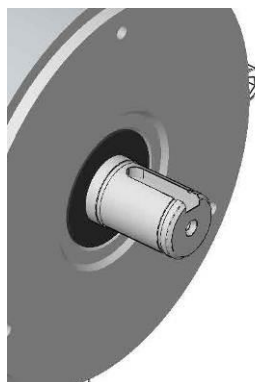
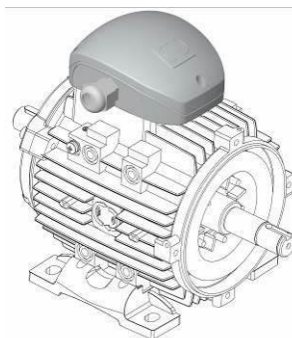

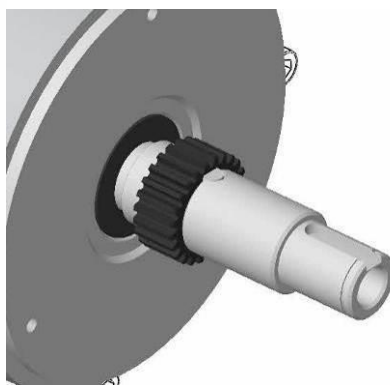
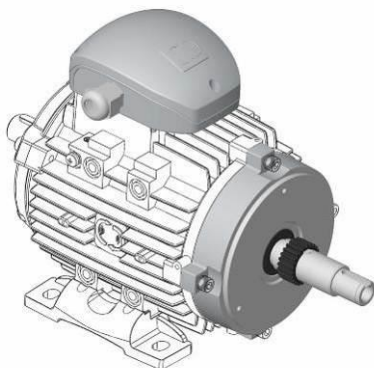
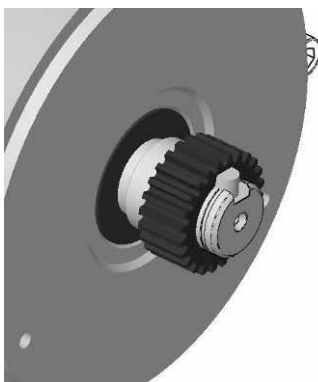
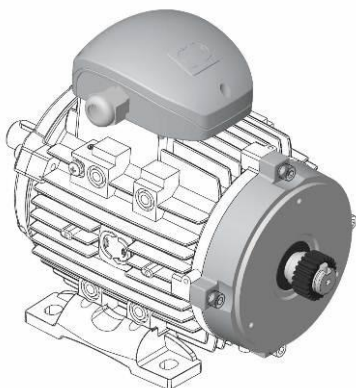
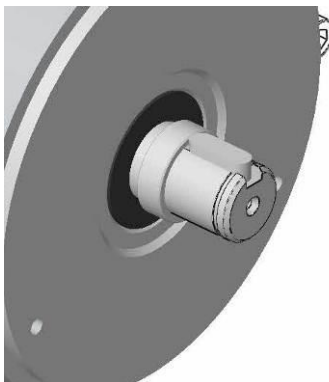
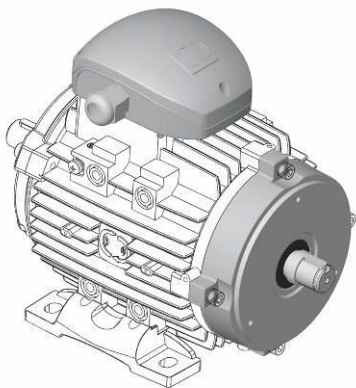



motor type	DH
90	M8X19
100	M10X22
112	M10X22
132	M12X28
160	M16X36

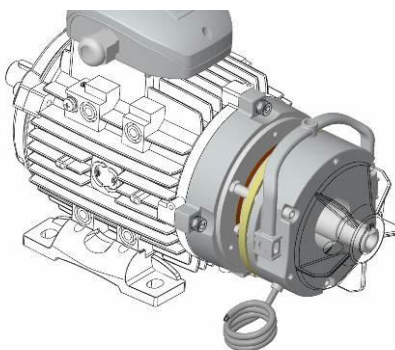
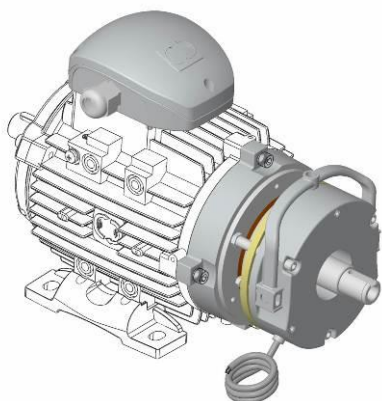
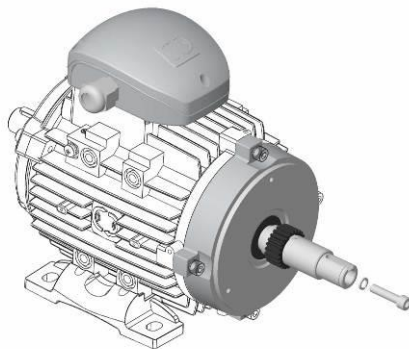



AT24:

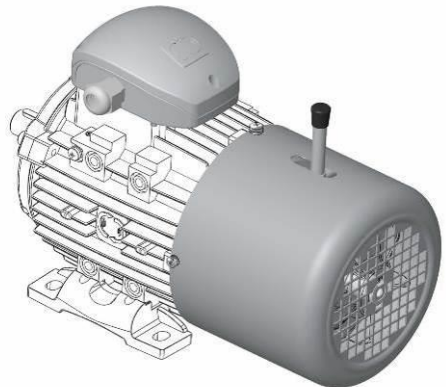
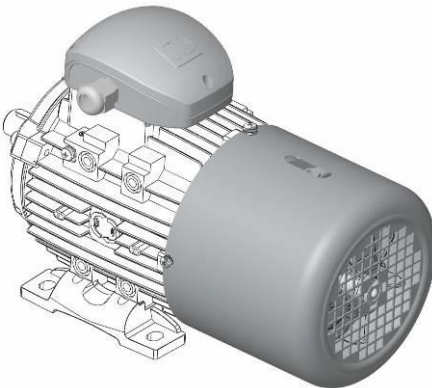
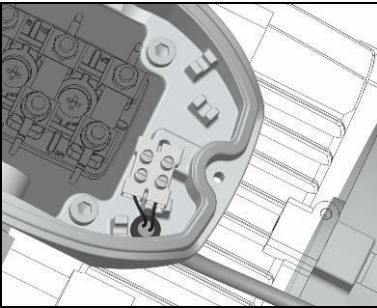
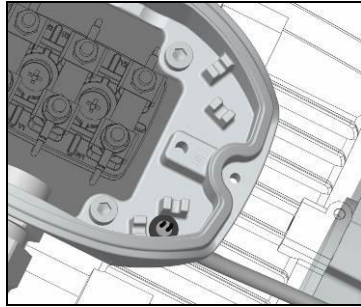
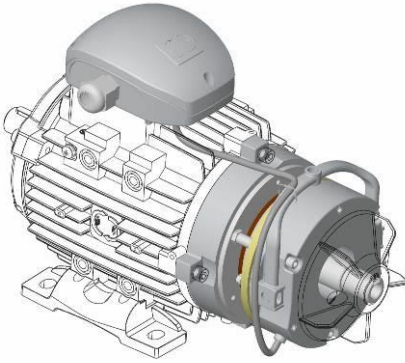



ATDC:

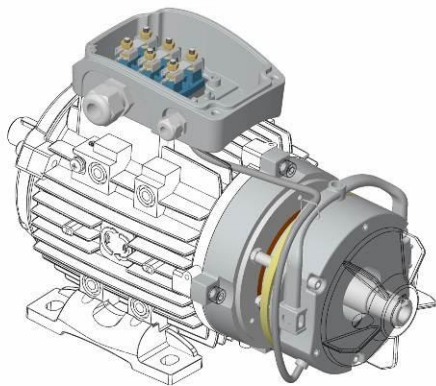
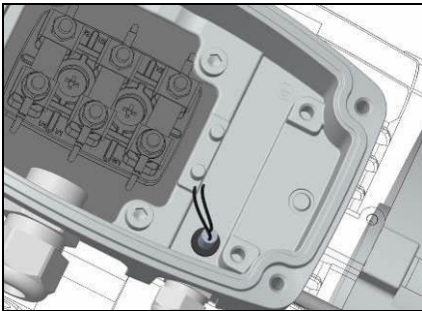
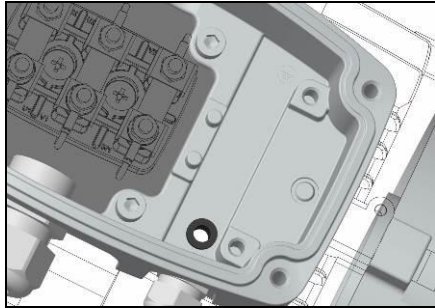
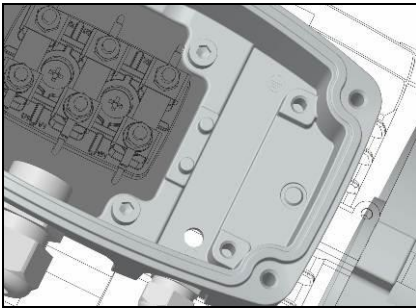
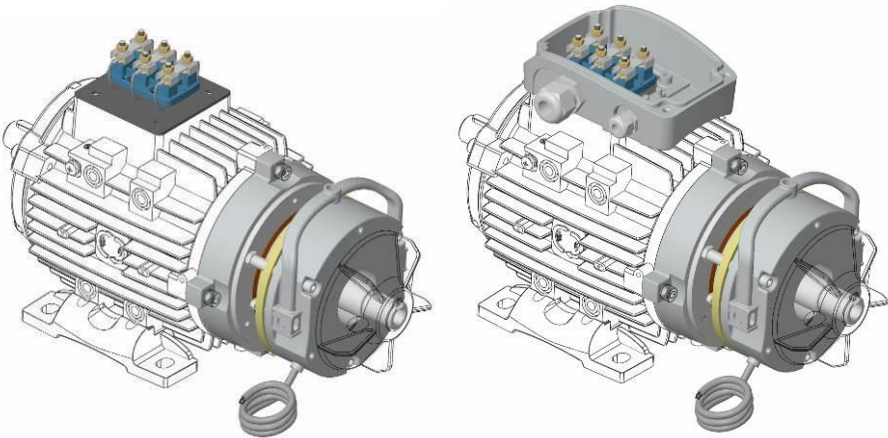

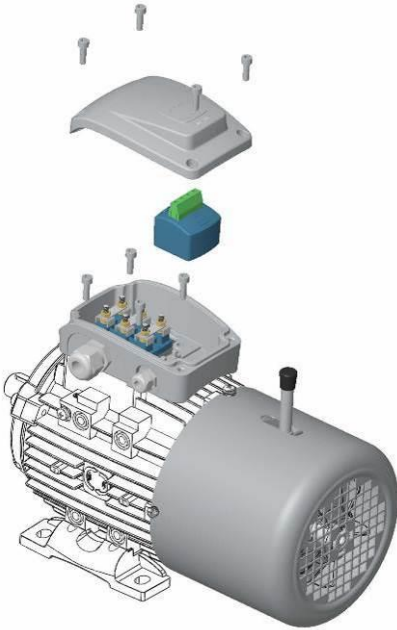

(See Fig 1-7)

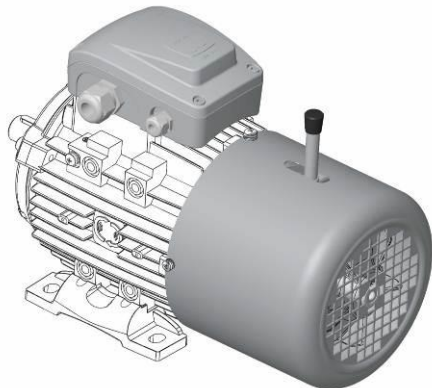
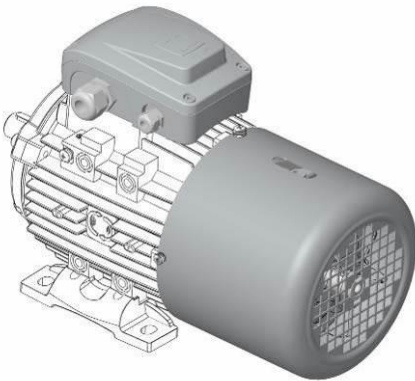
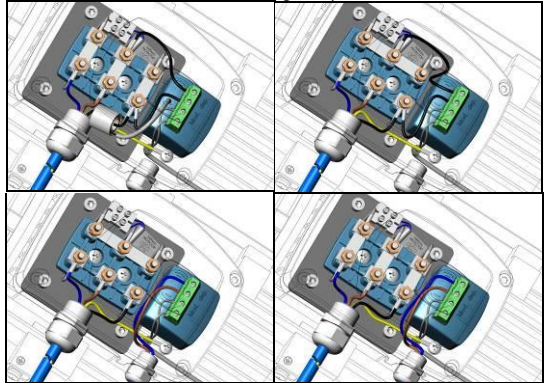



Assisted power cooling SV series

For applications with a power supply below a frequency of 50Hz, the appropriate assisted power cooling must be mounted as there are too many variables involved to determine the various possible thermal duties, and thus the temperatures reached by the motors

Motori servoventilati Serie SV

Per applicazioni con coppia nominale al di sotto della velocità a 50Hz del motore, si impone il montaggio della servoventilazione adeguata, in quanto sono troppe le variabili in gioco per la determinazione dei vari servizi termici possibili e quindi le temperature raggiunte dai motori

NB: la tabella fa riferimento a motori per utilizzo a temperatura ambiente massimo 40°C.
Per applicazioni a temperature ambiente diverse, consultare il nostro reparto tecnico.

The table refers to motors for use at a maximum ambient temperature of 40°C.
For applications at different ambient temperatures, please consult our technical department.

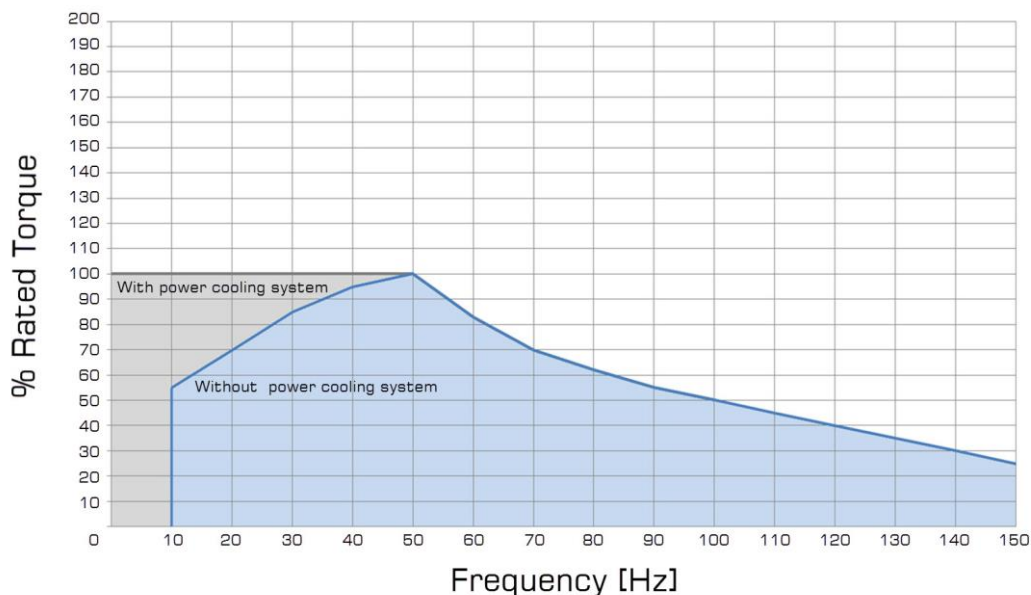



Encoder

A seconda del tipo di ventilazione, l'encoder può essere montato dalla Motive nei due modi rappresentati di seguito.

Motive raccomanda encoder di propria selezione, le cui caratteristiche vengono segnalate in fase d'ordine.

According to the requested ventilation, encoders can be mounted by Motive in the 2 following ways.

Motive recommends the encoder types that it selected. Their features can be communicated upon request.

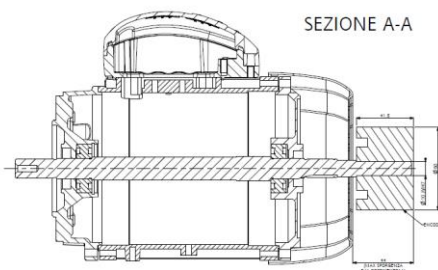
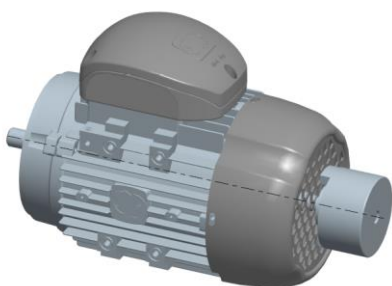
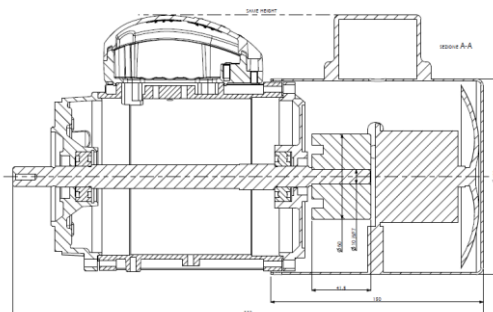
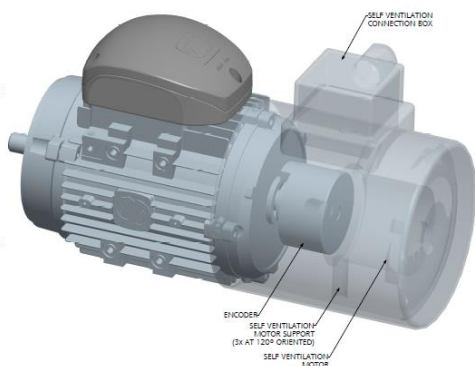



Trasporto, conservazione, uso e manutenzione

La Motive srl fornisce i motori in imballi idonei ad ogni tipo di trasporto.

Prima di ogni intervento assicurarsi che l'alimentazione elettrica sia disconnessa.

Usare solo ricambi originali

Il motore deve essere conservato in ambiente coperto, asciutto, privo di vibrazioni e polvere, a temperatura superiore a -15°C .

Le parti esposte, come flange ed estremità dell'albero, devono essere protette con lubrificante. È opportuno ruotare periodicamente l'albero per assicurare nel tempo la completa lubrificazione dei cuscinetti.

Il motore deve essere installato e utilizzato da personale qualificato e a conoscenza dei requisiti di sicurezza. Anche le operazioni di installazione devono avvenire in ambiente asciutto e protetto dagli agenti atmosferici. La temperatura e l'umidità di esercizio deve essere compresa nei limiti descritti nel precedente paragrafo "condizioni di funzionamento". Lo smontaggio e l'assemblaggio del motore devono essere effettuati da personale qualificato. Qualsiasi intervento sulla scatola coprimorsettiera deve essere effettuato solo dopo aver interrotto l'alimentazione.

Eventuali ispezioni devono essere eseguite con l'uso di appositi strumenti (estrattori), evitando l'uso di attrezzi che possano arrecare danni al motore, quali martelli o attrezzi ad impatto. È opportuno eseguire ispezioni periodiche, per garantire le migliori condizioni di lavoro, effettuando: pulizia del motore, verifica della ventilazione, identificazione di eventuali rumori anomali e vibrazioni. In questo caso controllare i cuscinetti (vedi la tabella nr 1) e, se necessario, sostituirli, come pure il paraolio.

Verificare infine il corretto fissaggio del motore sulla flangia o sui piedini.

I motori non devono essere immagazzinati in ambienti con rischio di esplosione.

Prima di utilizzare il motore, pulire le connessioni di terra e l'involucro da eventuali residui di polveri e/o tracce di ossidazione.



Raccomandazioni speciali per motori atex

Tutte le operazioni di verifica e manutenzione dei motori devono essere eseguite in modo da rispettare la Norma EN 60079-17. In particolar modo bisogna prestare attenzione che tutte le viterie devono essere serrate a fondo.

La sostituzione di alcune parti soggette ad usura (es. guarnizioni di tenuta sull'albero, cuscinetti) deve essere effettuata con componenti identici a quelli forniti dal costruttore al fine di garantirne il mantenimento dei requisiti di sicurezza e del grado di protezione.



La superficie dei giunti (es. accoppiamento carcassa/scudi; giunti passaggio d'albero) **NON DEVONO ESSERE NÉ LAVORATE NÉ VERNICIATE**. Tali superfici devono essere tenute pulite e, contro la corrosione o l'ingresso di acqua, deve essere mantenuto sulle stesse un velo di grasso silconico

Le riparazioni dei motori ATEX devono essere eseguite secondo quanto prescritto nella norma IEC 79-19, e possono essere svolte "solamente dal costruttore" o da officine autorizzate dal costruttore stesso

Avvertenze per l'installazione

Per l'installazione del motore, è consigliabile attenersi alle seguenti indicazioni:

- verificare che non vi siano stati danni durante il trasporto;
- pulire adeguatamente i componenti dell'impianto da residui dell'imballaggio e da eventuali prodotti protettivi;
- verificare che il valore della tensione di alimentazione stampigliata sulla targhetta del motore, coincida con la tensione di rete;
- la verniciatura non deve interessare le superfici di contatto dei collegamenti equipotenziali e la targhetta di identificazione;
- installare il motore su una superficie piana;
- accertarsi che i piedini o la flangia siano ben serrati e che, nel caso di giunto diretto, il motore sia perfettamente allineato;
- far ruotare manualmente l'albero per verificare l'assenza di rumori da strisciamento;
- verificare il senso di rotazione con trasmissione disinnestata;
- calettare (estrarre) gli elementi condotti (es. puleggia per trasmissione a cinghia, giunto, ecc.), solo mediante dispositivi appositi (calettamento a caldo). Evitare tensioni non consentite sulla puleggia (rif. catalogo par. distinta tecnica);
- non ostacolare la ventilazione. L'aria scaricata, compresa quella proveniente da altri gruppi, non deve essere subito riaspirata;
- verificare la corretta messa a terra del motore



Messa a terra (DELPHI 3PH)

La messa a terra può essere fatta sia all'interno del coprimorsettiera (fig.1) che utilizzando l'apposito fissaggio sulla carcassa (fig.2). Quest'ultimo tipo di connessione può essere richiesto nel caso in cui il cavo di connessione alla morsettiera manchi del 4° filo per la terra, oppure perché prescritto da apposite normative (es. ATEX), o per collegare in serie la messa a terra di più motori da carcassa a carcassa, o in prodotti customizzati senza morsettiera.

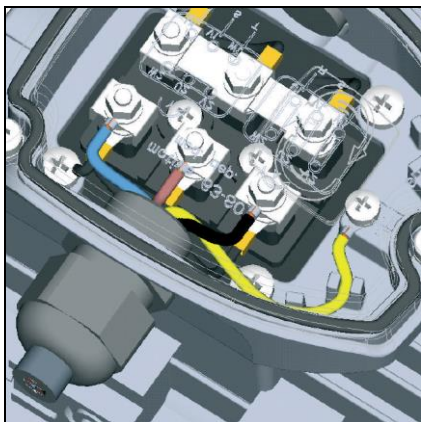

Fig.1

Earth connection (DELPHI 3PH)

Earth connection can be done either inside the terminal box (Fig.1) or by using the screw on the housing (Fig.2). This last connection can be requested when the cable going into the terminal box is a 3 wires cable, without the earth one, or when prescribed by some norms (like ATEX), or to connect in series several motors earth by connecting their frames each-other, or in customized motors without terminal block and terminal box.

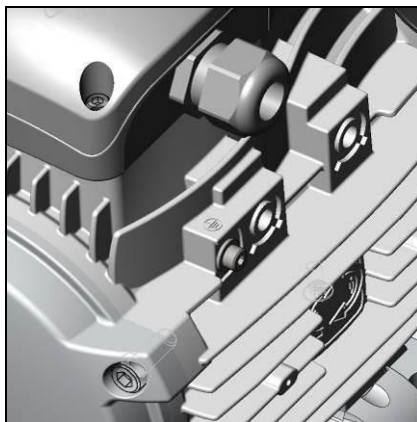

Fig.2



Transportation, conservation, use and maintenance

Motive dispatches the motors in packagings suitable for any kind of transportation.

Before any maintenance intervention make sure that the power supply of the motor is off disabling it;

Use only original spare parts following the indications provided in the catalogue for the motors;

The motor must be conserved in covered and dry ambient, without the presence of vibrations or dust, a temperature higher then -15°C .

The exposed parts, like flanges and the shaft drive extremity, must be protected by lubricant. It is opportune to rotate periodically the shaft in order to ensure a long-standing complete lubrication of the bearings.

The motor must be installed and used by qualified people that know the safety requirements. Also the installation must happen in dry climate and protected by atmospheric agents. The working temperature and humidity must be within the limits described in the previous paragraph "working conditions". Motor dismantling and assembling must be done by qualified people. Any intervention on the connection box must be done only after having disconnected the power supply.

Eventual inspections must be done with proper tools, avoiding means that could damage the motor. It is opportune to make periodical inspections, to guarantee the best working conditions and making: motor cleaning, fan cooling verification, eventual abnormal noise and vibration identification. In this last case, check the bearings (see tab.1) and, if necessary, substitute them, as well as the rubber seal rings.

Finally, verify the correct fixture of the motor on the flange or on the feet.



Recommended precautions for ATEX motors

All maintenance and control operations on ATEX motors must be done respecting the standard EN 60079-17. Pay attention that all screws are closed tightly.

The replacement of parts subject to wear, (like bearings and oil seals, must be done using only original spare parts in order to preserve the safety requirements and protection degree.

The joints surfaces (for instance between housing and shields, shaft) must not be neither machined nor painted. Such surfaces must be kept clean and, against corrosion and water entry, you must keep on the same a layer of silicon grease.

Repair of ATEX motors must be done respecting the norm IEC 79-19, and they can be done only by the manufacturer or by trained and authorized external workshops.



Installation precautions

For the installation of the motor please consider the following:

- make sure that no damages have occurred during transportation;
- carefully remove the components of the plant from the wrapping material and any other protective devices;
- make sure that the value of the voltage on the rating plate is the same as the voltage of mains;
- the surfaces in contact with the electric bonding and the rating plate must not be varnished;
- set the motor on a flat surface;
- make sure that the bearings or the flange are well fixed and that in case of direct joint the motor is perfectly aligned;
- make the rotor rotate manually in order to verify the absence of any dragging;
- verify the rotation sense removing the joint;
- key (extract) the output components (i.e. joint, belt pulley, etc.) only using apt devices (shrinking-on). Avoid not allowed tension on the pulley (ref. catalogue par. technical sheet);
- in the models in which the shaft is with the end downwards, use the protective cover. If the end of the shaft is upwards, use a cover preventing any penetration of external parts into the fan;
- do not hinder ventilation. The discharged air, together with the air coming from other groups, must not be immediately re-aspirated;
- verify the correct grounding of the motor



Lubrificazione cuscinetti (DELPHI 3PH)

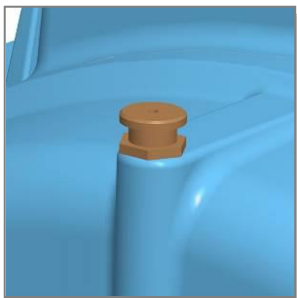

I motori con cuscinetti stagni autolubrificati a vita non richiedono lubrificazione. La durata dei cuscinetti varia dai 3 ai 5 anni a seconda dei carichi assiali e radiali applicati all'albero e secondo le condizioni ambientali di impiego del motore. I motori previsti con il dispositivo di lubrificazione dei cuscinetti devono essere lubrificati con il motore in moto secondo gli intervalli di lubrificazione e la quantità indicati



nella tabella 2. Sui cuscinetti speciali a rulli "NU"

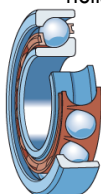

e a contatto obliquo "7.." fuori standard, gli intervalli di lubrificazione della tabella 2 si dimezzano.

Gli intervalli di lubrificazione si dimezzano anche per motori alimentati da inverter ... causa vetrificazione del grasso per passaggio corrente tra rotore e statore. Per questo motivo, sono raccomandati per questi motori alimentati da inverter i cuscinetti isolati (esecuzione speciale), soprattutto su motori da 110kW in su.



Si può usare grasso al litio o polyurea con olio di base minerale adatto ad una temperatura max di esercizio di ameno 190°C. Comunque, motive raccomanda Mobil Polyrex EM o Mobil Mobilith SHC per la massima durata

Bearings lubrication (DELPHI 3PH)

Motors with staunch bearings, that are self-lubricating for life, do not require any lubrication. Bearings life vary from 3 up to 5 years according to the axial and radial loads that are charged on the shaft and to environmental conditions the motor is used in.

Motors from size 180 provided with the bearings lubrication unit are to be lubricated while running according to the lubricating intervals and the grease quantity as per table 2.

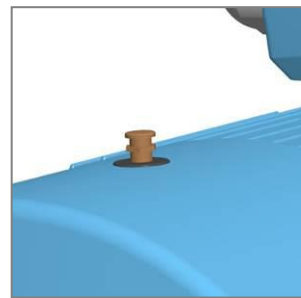



On non-standard roller "NU" bearings and Angular contact ball bearings "7.."

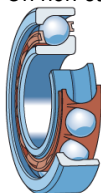

, the lubrication intervals timing is half.

Lubrication intervals timing is half also for motors supplied by inverter, because of the grease vetrification caused by the currents arc between stator and rotor. For this reason, insulated



bearings (special execution) are recommended on such motors, especially when their power is 110kW or higher

Use lithium o polyurea grease with mineral oil basis suitable for a max working temp. of at least 190°C. By the way, we recommend Mobil Polyrex EM or Mobil Mobilith SHC for the max durability

Tab. 2

motore motor	Quantità grasso (g) Grease quantity (g)		Intervalli di lubrificazione in ore operative Lubrication intervals in operation hours			
	2 poli 2 poles	4-6-8 poli 4-6-8 poles	2 Poli 2 Poles	4 Poli 4 Poles	6 Poli 6 Poles	8 Poli 8 Poles
180-200*	25		3800	9300	12400	15200
225*	25		3800	8900	12200	14800
250*	30		3100	4100	5900	6900
280*	28	36	800	3900	5600	6700
315	36	45	800	2300	4100	5100
355	45	60	700	2000	4000	4500

***Ingrassaggio cuscinetti motori 180-280 *180-280 motors bearings lubrication**



I motori dalla taglia 180 fino alla taglia 280, dal 2017 sono provvisti di cuscinetti chiusi autolubrificati e, quindi, esenti da manutenzione x ingrassaggio periodico

NB: durante gli anni 2016-2017, i motori 180-280 potrebbero essere dotati di ingrassatori e cuscinetti aperti, per i tempi di aggiornamento prodotto.

From size 160 up to 280, since 2017, we mount ZZ auto-lubricated bearings, thus avoiding the need of a periodical re-greasing maintenance

Note: during the years 2016 and 2017, the motors size 180-280 might still be equipped by lubricators and open bearings, because of the time needed to update them.

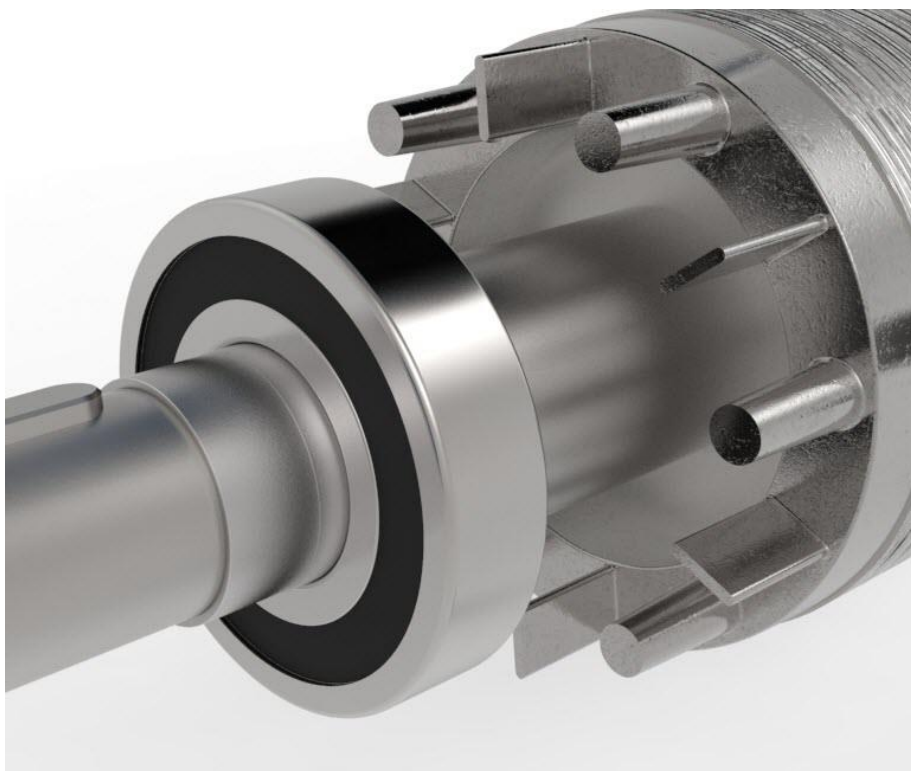



Lista ricambi - Spare parts list

DELPHI (3PH)

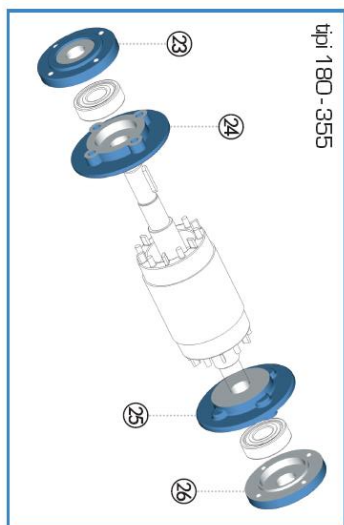
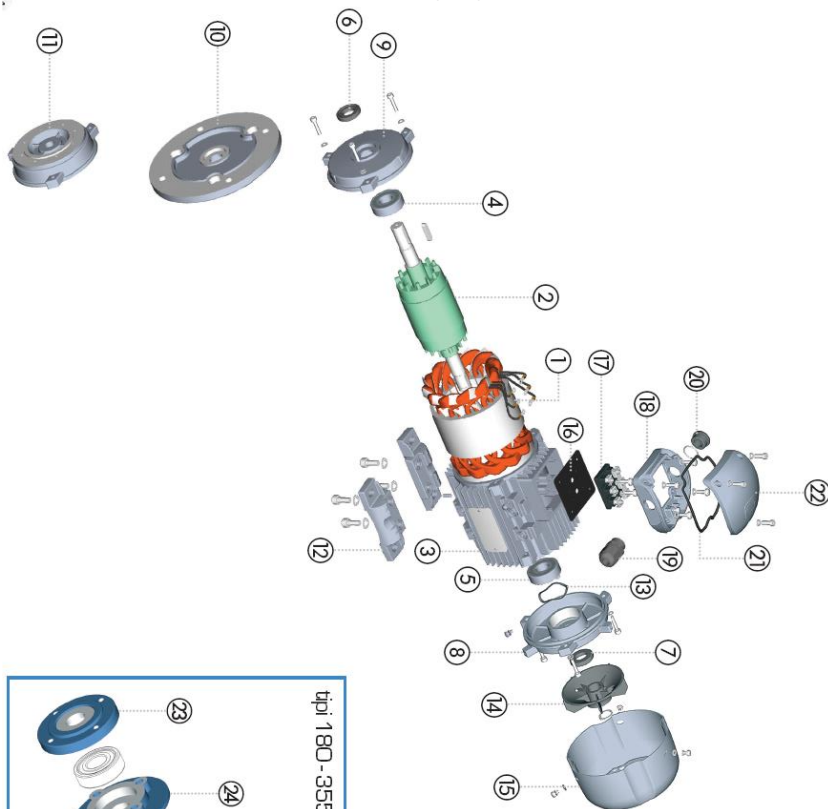

N°	CODICE
1	3PNSTA
2	3PNFOT
3	3PNFRA
4	3PNFBE
5	3PNBEB
6	3PNFOS
7	3PNBOS
8	3PNESH
9	3PNBOS
10	3PNBOS
11	3PNB14
12	3PNFEE
13	3PNVAW

N°	CODICE
14	3PNFAN
15	3PNFCV
16	3PNUD8
17	3PNTER
18	3PNB08
19	3PNVMP
20	3PNCAP
21	3PNSO8
22	3PNDO8
23	3PNF08
24	3PNFEB
25	3PNBEB
26	3PNB08

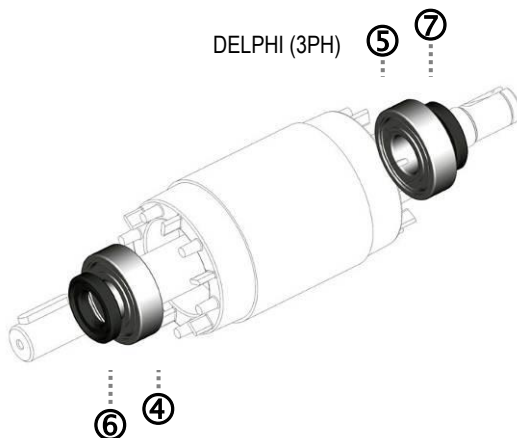

Tipo	Poli	Paraolio - Rubber seal ring		Cuscinetti - Bearings		
Type	poles	⑥	⑦	④	⑤	
					standard	AT...
56	2 - 8	12x25x7	12x25x7	6201 ZZ-C3	6201 ZZ-C3	=
63	2 - 8	12x25x7	12x25x7	6201 ZZ-C3	6201 ZZ-C3	=
71	2 - 8	15x30x7	15x30x7	6202 ZZ-C3	6202 ZZ-C3	=
80	2 - 8	20x35x7	20x35x7	6204 ZZ-C3	6204 ZZ-C3	=
90	2 - 8	25x40x7	25x40x7	6205 ZZ-C3	6205 ZZ-C3	=
100	2 - 8	30x47x7	30x47x7	6206 ZZ-C3	6206 ZZ-C3	=
112	2 - 8	30x47x7	30x47x7	6206 ZZ-C3	6206 ZZ-C3	6306 ZZ-C3
132	2 - 8	40x62x8	40x62x8	6208 ZZ-C3	6208 ZZ-C3	=
160	2 - 8	45x62x8	45x62x8	6309 ZZ-C3	6309 ZZ-C3	=
180	2 - 8	55x72x8	55x72x8	6311 ZZ-C3	6311 ZZ-C3	=
200	2 - 8	60x80x8	60x80x8	6312 ZZ-C3	6312 ZZ-C3	=
225	2 - 8	65x80x10	65x80x10	6313 ZZ-C3	6313 ZZ-C3	=
250	2 - 8	70x90x10	70x90x10	6314 ZZ-C3	6314 ZZ-C3	=
280	2	70x90x10	70x90x10	6314 ZZ-C3	6314 ZZ-C3	=
280	4 - 8	85x100x12	80x100x12	6317 ZZ-C3	6317 ZZ-C3	=
315	2	85x110x12	85x110x12	6317-C3	6317-C3	
315	4 - 8	95x120x12	95x120x12	NU 319-C3	6319-C3	
355	2	95x120x12	95x120x12	6319-C3	6319-C3	
355	4 - 8	110x130x12	110x130x12	NU 322-C3	6322-C3	
400	4 - 8	130x160x12	130x160x12	NU 326-C3	6326-C3	



MONO (1PH)

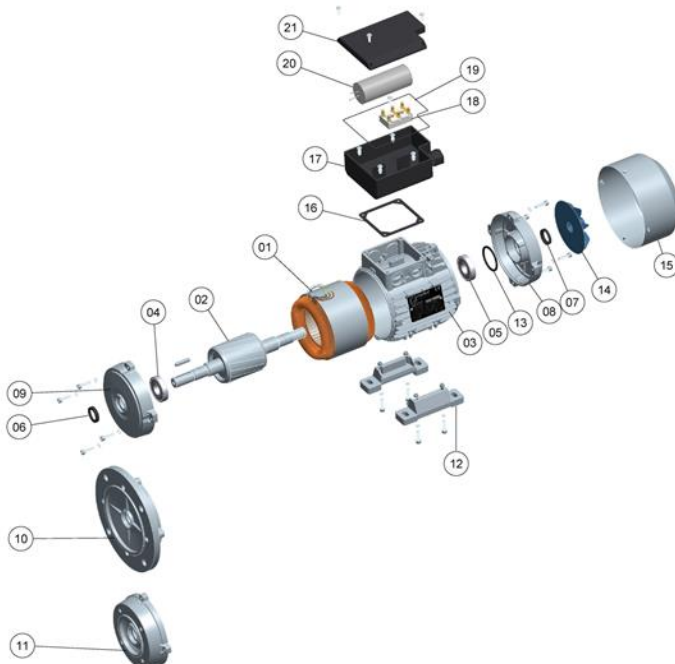

N°	CODICE
1	1PNSTA
2	1PNTOR
3	1PNFRA
4	1PNFBE
5	1PNBBE
6	1PNFOS
7	1PNBOS
8	1PNBSH
9	1PNB03
10	1PNB05
11	1PNB14
12	1PNFEE
13	1PNWAV
14	1PNFAN
15	1PNFCV
16	1PNUCB
17	1PNBCB
18	1PNTER
19	1PNSCB
20	1PNCON
21	1PNCCB



MONO (1PH)

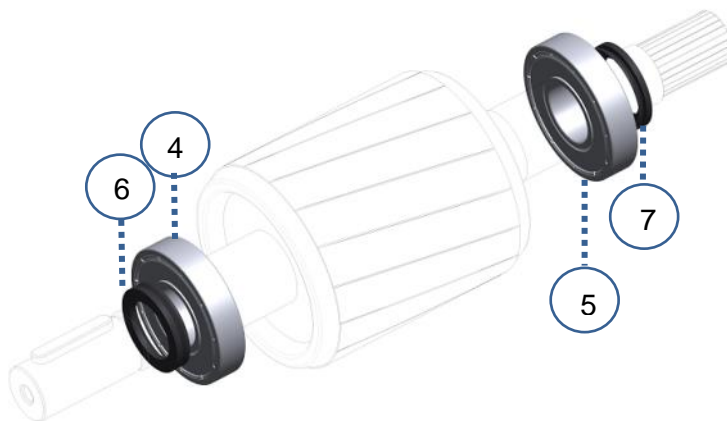

Tipo	Poli	V Ring		Cuscinetti - Bearings	
Type	poles	⑥	⑦	④	⑤
63	2-4	VR14	VR14	6202ZZ	6202ZZ
71	2-4	VR14	VR14	6202ZZ	6202ZZ
80	2-4	VR19	VR19	6204ZZ	6204ZZ
90	2-4	VR24	VR24	6205ZZ	6205ZZ
100	2-4	VR28	VR28	6206ZZ	6206ZZ
112	2-4	VR28	VR28	6306ZZ	6306ZZ



carichi massimi – max admitted loads

DELPHI (3PH)

	Fr [N] standard				Fa1 / Fa2 [N] standard				Fa1 / Fa2 [N] special option			
	3000rpm	1500rpm	1000rpm	750rpm	3000rpm	1500rpm	1000rpm	750rpm	3000rpm	1500rpm	1000rpm	750rpm
56	275	380			120	180			380	500		
63	300	375			120	180			380	500		
71	330	410	480	500	200	280	300	320	640	800	980	1000
80	550	680	800	900	280	340	400	460	880	1180	1370	1440
90	600	770	880	980	340	480	480	650	1480	2000	2480	2080
100	880	1100	1250	1400	480	580	750	850	1980	2410	3070	2900
112	1000	1200	1400	1500	480	580	750	850	1980	2410	3070	3700
132	1350	1700	1950	2200	600	1000	1300	1500	1110	1840	2390	6130
160	2300	2700	3000	3200	1300	1500	1900	2200	1990	2290	2900	8980
180	3000	4000	4600	5300	2400	2700	3000	3300	3860	4000	4450	6070
200	3800	4800	5500	5500	3000	3900	4800	4800	3700	4810	5920	7320
225	4200	5200	6000	6000	3600	4900	5700	5700	5400	7350	8550	8450
250	4800	6000	6900	6900	4100	5500	6500	6500	5930	7950	9380	8010
280	4800	7800	8900	8900	4200	6800	8800	8800	6070	9830	9830	10200
315	5800	15000	15000	17500	4800	7000	7000	7000	6580	10000	10000	10120
355	7700	19000	19000	19000	5800	7200	7200	7200	7740	9800	9800	10400
400	9000	20500	20500		7900	12500	14800		9860	17050	19910	

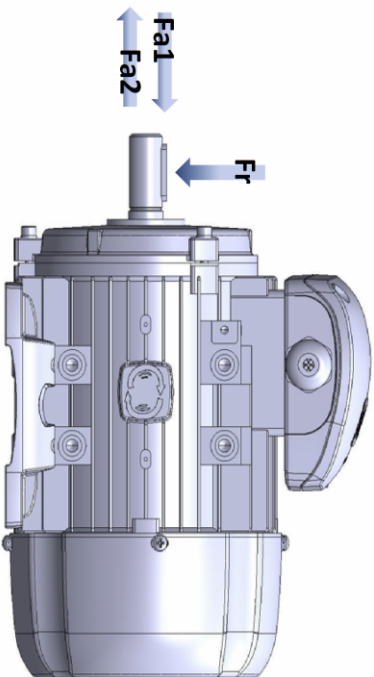



MONO (1PH)

	Fr [N]		Fa1 [N]		Fa2 [N]	
	3000rpm	1500rpm	3000rpm	1500rpm	3000rpm	1500rpm
56	275	360	120	160	120	160
63	300	375	120	160	120	160
71	330	410	200	250	200	250
80	550	690	260	340	260	340
90	600	770	340	460	340	460
100	880	1100	480	590	480	590
112	1000	1200	480	700	480	700

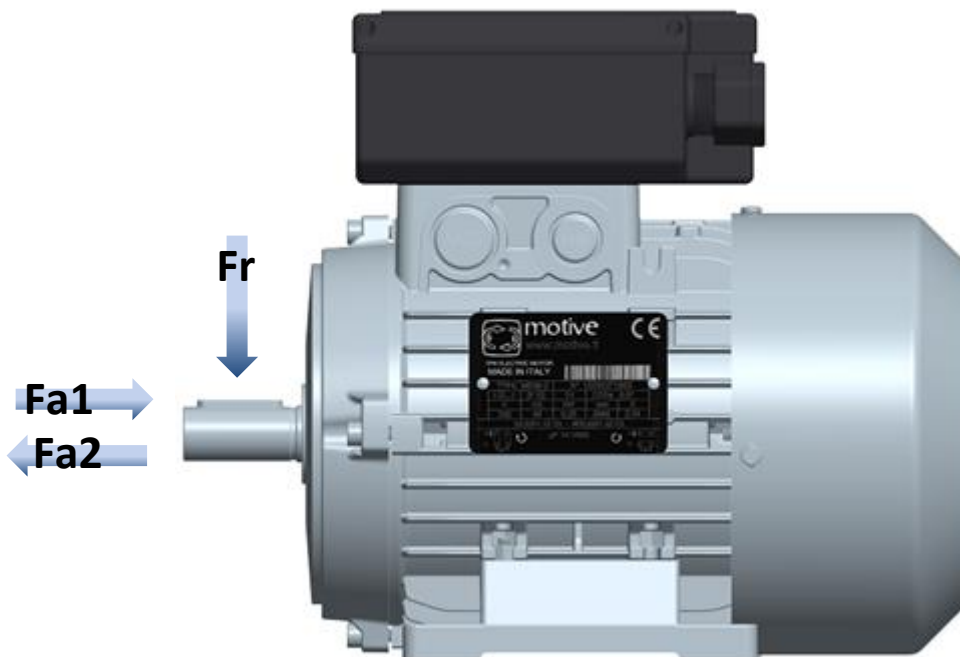



Motive s.r.l.
Via Le Ghiselle, 20
25014 Castenedolo (BS)
Tel.: +39 030 2677087
Fax: +39 030 2677125
motive@motive.it



Dichiarazione di conformità

La ditta Motive s.r.l. con sede in Castenedolo (BS) - Italia

dichiara, sotto la sua esclusiva responsabilità,

che la sua intera gamma di **motori elettrici asincroni trifase IEC 56-400 serie DELPHI e DELFIRE**

è costruita e collaudata in conformità con la seguente normativa internazionale (ult. ediz.)

- EN60034-1** Macchine elettriche rotanti - Parte 1: Caratteristiche nominali e di funzionamento
- EN60034-6** Macchine elettriche rotanti - Parte 6: Sistemi di raffreddamento
- EN60034-7** Macchine elettriche rotanti - Parte 7: Classificazione delle forme costruttive e dei tipi di installazione nonché posizione delle morsettiere (Codice IM)
- EN60034-8** Macchine elettriche rotanti - parte 8: Marcatura dei terminali e senso di rotazione
- EN60034-25** Macchine elettriche rotanti-Parte 25: Guida per la progettazione e le prestazioni dei motori in corrente alternata specificamente progettati per l'alimentazione da convertitori
- EN60034-2-1** Macchine elettriche rotanti: Metodi di prova per determinare le perdite e l'efficienza
- EN60034-30-1** Macchine elettriche rotanti-Parte 30: Classi di rendimento dei motori a corrente alternata alimentati dalla rete (Codice IE)
- EN50347** Motori asincroni trifase di uso generale con dimensioni e potenze normalizzate - Grandezze da 56 a 315 e numeri di flangia da 65 a 740
- EN61000-6-4** Compatibilità elettromagnetica (EMC): Parte 6-4: Norme generiche - Emissioni per gli ambienti industriali
- IEC 72-1** Dimensions and output series for rotating electrical machines Part 1: Frame numbers 56 to 400 and flange numbers 55 to 1080

come richiesto dalle Direttive

Bassa Tensione (LVD) 2014/35/EU,
EMC Compatibilità Elettromagnetica (EMC) 2014/30/EU
ErP progettazione ecocompatibile dei prodotti (ErP) 2019/1781/EU

Il motore non deve funzionare finché la macchina ove viene assemblato viene dichiarata conforme alla **Direttiva Macchine 2006/42/EU**

Il Rappresentante Legale: Giorgio Bosio

N. REA 422301
Cod. Fisc. e P. IVA 03580280174



Motive s.r.l.
Via Le Ghiselle, 20
25014 Castenedolo (BS)
Tel.: +39 030 2677087
Fax: +39 030 2677125
motive@e-motive.it



Conformity Declaration

Motive s.r.l. whose Head Office is situated in Castenedolo (BS) - Italy

declares, under its own exclusive responsibility,

that its whole range of

asynchronous electric motors of the series "Delphi" and "DELFIRE"

is designed, produced and tested according to the following international norms (last issue):

- EN60034-1** Rotating Electrical Machines - Part 1: Rating and performance
- EN60034-6** Rotating Electrical Machines - Part 6: Methods of cooling (IC code)
- EN60034-7** Rotating Electrical Machines - Part 7: Classification of Types of Construction, Mounting Arrangements and Terminal Box Position (IM Code)
- EN60034-8** Rotating electrical machines – Part 8: Terminal markings and direction of rotation
- EN60034-25** Rotating electrical machines - Part 25: Guidance for the design and performance of a.c. motors specifically designed for converter supply
- EN60034-2-1** Rotating electrical machines. Standard methods for determining losses and efficiency from tests
- EN60034-30-1** Rotating electrical machines - Part 30: Efficiency classes of single-speed, three-phase, cage-induction motors
- EN50347** General purpose three-phase induction motors having standard dimensions and outputs. Frame numbers 56 to 315 and flange numbers 65 to 740
- EN61000-6-4** Electromagnetic compatibility (EMC) - Part 6: Generic standards - Section 4: Emission standard for industrial environments
- IEC 72-1** Dimensions and output series for rotating electrical machines Part 1: Frame numbers 56 to 400 and flange numbers 55 to 1080

following the provisions of the Directives

Low Voltage (LVD) 14/35/EEC,
EMC Electromagnetic Compatibility (EMC) 14/30/EEC
Eco-design Directive for Energy-related Products (ErP) 19/1781/EEC

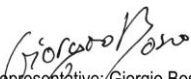
The Legal Representative: Giorgio Bosio

N. REA 422301
Cod. Fisc. e P. IVA 03580280174



Motive s.r.l.
Via Le Ghiselle, 20
25014 Castenedolo (BS)
Tel.: +39 030 2677087
Fax: +39 030 2677125
motive@e-motive.it



Conformity Declaration

Motive s.r.l. whose Head Office is situated in Castenedolo (BS) - Italy

declares, under its own exclusive responsibility,

that its whole range of

asynchronous electric motors of the series "Delphi" and "DELFIRE"

is designed, produced and tested according to the following international norms (last issue):

BS EN 60034-1	Rotating Electrical Machines - Part 1: Rating and performance
BS EN 60034-6	Rotating Electrical Machines - Part 6: Methods of cooling (IC code)
BS EN 60034-7	Rotating Electrical Machines - Part 7: Classification of Types of Construction, Mounting Arrangements and Terminal Box Position (IM Code)
BS EN 60034-8	Rotating electrical machines – Part 8: Terminal markings and direction of rotation
CLC/TS EN 60034-25	Rotating electrical machines - Part 25: Guidance for the design and performance of a.c. motors specifically designed for converter supply
BS EN 60034-2-1	Rotating electrical machines. Standard methods for determining losses and efficiency from tests
BS EN 60034-30-1	Rotating electrical machines - Part 30: Efficiency classes of single-speed, three-phase, cage-induction motors
BS EN 50347	General purpose three-phase induction motors having standard dimensions and outputs. Frame numbers 56 to 315 and flange numbers 65 to 740
BS EN 61000-6-4	Electromagnetic compatibility (EMC) - Part 6: Generic standards - Section 4: Emission standard for industrial environments
IEC 72-1	Dimensions and output series for rotating electrical machines Part 1: Frame numbers 56 to 400 and flange numbers 55 to 1080

following the provisions of the Directives

Low Voltage (LVD) **14/35/EEC**,
UK Electrical Equipment (Safety) **Regulations 2016**

EMC Electromagnetic Compatibility (EMC) **14/30/EEC**
UK EMC Electromagnetic Compatibility **Regulations 2016**

Eco-design Directive for Energy-related Products (ErP) **09/125/EEC**
UK The Ecodesign for Energy-Related Products and Energy Information (Amendment) (EU Exit) **Regulations 2019**

The Legal Representative: **Giorgio Bosio**

N. REA 422301
Cod. Fisc. e P. IVA 03580280174



Motive s.r.l.
Via Le Ghiselle, 20
25014 Castenedolo (BS)
Tel.: +39 030 2677087
Fax: +39 030 2671125
motive@motive.it



Dichiarazione di conformità

La ditta Motive s.r.l. con sede in Castenedolo (BS) - Italia
dichiara, sotto la sua esclusiva responsabilità,
che la sua intera gamma di **motori elettrici asincroni monofase serie MONO**
è costruita in conformità con la seguente normativa internazionale (ult. edizione)

- EN60034-1** Macchine elettriche rotanti - Parte 1: Caratteristiche nominali e di funzionamento
- EN60034-6** Macchine elettriche rotanti - Parte 6: Sistemi di raffreddamento
- EN60034-7** Macchine elettriche rotanti - Parte 7: Classificazione delle forme costruttive e dei tipi di installazione nonché posizione delle morsettiere (Codice IM)
- EN60034-8** Macchine elettriche rotanti - parte 8: Marcatura dei terminali e senso di rotazione
- EN50347** Motori asincroni trifase di uso generale con dimensioni e potenze normalizzate - Grandezze da 56 a 315 e numeri di flangia da 65 a 740
- EN61000-6-4** Compatibilità elettromagnetica (EMC): Parte 6-4: Norme generiche - Emissione per gli ambienti industriali
- IEC 72-1** Dimensions and output series for rotating electrical machines Part 1: Frame numbers 56 to 400 and flange numbers 55 to 1080

come richiesto dalle Direttive

BT Bassa Tensione CEE 14/35,
EMC Compatibilità Elettromagnetica CEE 14/30

Il motore non deve funzionare finché la macchina ove viene assemblato viene dichiarata conforme alla **Direttiva Macchine CEE 06/42**
NB: la Direttiva Macchine espressamente esclude dal suo campo di applicazione i motori elettrici (Art.1, comma 2)

Il Rappresentante Legale: Giorgio Bosio

N. REA 422301
Cod. Fisc. e P. IVA 03580280174



Motive s.r.l.
Via Le Ghiselle, 20
25014 Castenedolo (BS)
Tel.: +39 030 2677087
Fax: +39 030 2677125
motive@e-motive.it



Conformity Declaration

Motive s.r.l. whose Head Office is situated in Castenedolo (BS) - Italy

declares, under its own exclusive responsibility,

that its whole range of

single phase asynchronous electric motors of the series "MONO"

is conform to the following international norms (last issue):

- EN60034-1** Rotating Electrical Machines - Part 1: Rating and performance
- EN60034-6** Rotating Electrical Machines - Part 6: Methods of cooling (IC code)
- EN60034-7** Rotating Electrical Machines - Part 7: Classification of Types of Construction, Mounting Arrangements and Terminal Box Position (IM Code)
- EN60034-8** Rotating electrical machines – Part 8: Terminal markings and direction of rotation
- EN60034-25** Rotating electrical machines - Part 25: Guidance for the design and performance of a.c. motors specifically designed for converter supply
- EN50347** General purpose three-phase induction motors having standard dimensions and outputs. Frame numbers 56 to 315 and flange numbers 65 to 740
- EN61000-6-4** Electromagnetic compatibility (EMC) - Part 6: Generic standards - Section 4: Emission standard for industrial environments
- IEC 72-1** Dimensions and output series for rotating electrical machines Part 1: Frame numbers 56 to 400 and flange numbers 55 to 1080

following the provisions of the Directives

Low Voltage 14/35 EEC,
EMC Electromagnetic Compatibility 14/30 EEC

It is also possible to incorporate them into machines conform to the **Machinery Directive 06/42/EEC**. Note: The Machinery Directive excludes from its scope the electric motors (Art.1, comma 2)

The Legal Representative: 
Giorgio Bosio

N. REA 422301
Cod. Fisc. e P. IVA 03580280174



Motive s.r.l.
Via Le Ghiselle, 20
25014 Castenedolo (BS)
Tel.: +39 030 2677087
Fax: +39 030 2677125
motive@e-motive.it



Conformity Declaration

Motive s.r.l. whose Head Office is situated in Castenedolo (BS) - Italy

declares, under its own exclusive responsibility,

that its whole range of

single phase asynchronous electric motors of the series "MONO"

is conform to the following international norms (last issue):

BS EN 60034-1	Rotating Electrical Machines - Part 1: Rating and performance
BS EN 60034-6	Rotating Electrical Machines - Part 6: Methods of cooling (IC code)
BS EN 60034-7	Rotating Electrical Machines - Part 7: Classification of Types of Construction, Mounting Arrangements and Terminal Box Position (IM Code)
BS EN 60034-8	Rotating electrical machines – Part 8: Terminal markings and direction of rotation
BS EN 60335-1	Household and similar electrical appliances – Safety
BS EN 50347	General purpose three-phase induction motors having standard dimensions and outputs. Frame numbers 56 to 315 and flange numbers 65 to 740
BS EN 61000-6-4	Electromagnetic compatibility (EMC) - Part 6: Generic standards - Section 4: Emission standard for industrial environments
IEC 72-1	Dimensions and output series for rotating electrical machines Part 1: Frame numbers 56 to 400 and flange numbers 55 to 1080

following the provisions of the Directives

Low Voltage (LVD) **14/35/EEC**,
UK Electrical Equipment (Safety) **Regulations 2016**

EMC Electromagnetic Compatibility (EMC) **14/30/EEC**
UK EMC Electromagnetic Compatibility **Regulations 2016**

The Legal Representative: 
Giorgio Bosio

N. REA 422301
Cod. Fisc. e P. IVA 03580280174



СИСТЕМА ДОБРОВОЛЬНОЙ СЕРТИФИКАЦИИ

«Старт»

Зарегистрирована в Едином реестре систем добровольной сертификации Федерального агентства по техническому регулированию и метрологии Российской Федерации (Росстандарт РФ)



ИСПЫТАТЕЛЬНАЯ ЛАБОРАТОРИЯ ОБЩЕСТВО С ОГРАНИЧЕННОЙ
ОТВЕТСТВЕННОСТЬЮ ИННОВАЦИОННЫЙ ЦЕНТР «КОЛИБРИ» (ООО ИЛЦ «КОЛИБРИ»)

109025, г. Москва, 8-й проезд Марьиной Рощи, дом 30, стр. 1,

тел. +7(499) 391-23-57, inbox@i1-sert.ru

АТТЕСТАТ АККРЕДИТАЦИИ № РОСС RU.31857.04ИЛЦ0.00063 действителен до 17.06.2022г.

ПРОТОКОЛ ИСПЫТАНИЙ № 199-04/2020 от 14.04.2020 года

Место проведения испытаний:	Испытательная лаборатория ООО ИЦ «КОЛИБРИ»
Заявитель:	Общество с ограниченной ответственностью "ПРИВОД ГРАНД РЕДУКТОР". Место нахождения и адрес места осуществления деятельности: Российская Федерация, Смоленская область, 214004, город Смоленск, улица Багратиона, дом 4, офис 46
Наименование продукции:	Электродвигатели (мотор-редукторы) асинхронные трехфазные общепромышленного назначения, рабочее напряжение 220/380В. Модели 56В-2
Изготовитель:	"Motive srl". Место нахождения и адрес места осуществления деятельности по изготовлению продукции: Via Le Ghiselle, 20 25014 Castenedolo (BS), Италия.
Технический регламент:	ТР ТС 004/2011 "О безопасности низковольтного оборудования",
Испытано согласно требованиям:	ТР ТС 004/2011 "О безопасности низковольтного оборудования",
Дата получения образца	31.03.2020г.

Настоящий протокол испытаний распространяется только на образцы, подвергнутые испытаниям



ЕВРАЗИЙСКИЙ ЭКОНОМИЧЕСКИЙ СОЮЗ ДЕКЛАРАЦИЯ О СООТВЕТСТВИИ



Заявитель Общество с ограниченной ответственностью "ПРИВОД ГРАНД РЕДУКТОР"

Место нахождения и адрес места осуществления деятельности: Российская Федерация, Смоленская область, 214004, город Смоленск, улица Багратиона, дом 4, офис 46, основной государственный регистрационный номер: 1166733076608, номер телефона: +79203158381, адрес электронной почты: privodgrand@gmail.com

в лице Директора Шелеста Александра Иосифовича

заявляет, что Электродвигатели (мотор-редукторы) асинхронные трехфазные общепромышленного назначения, рабочее напряжение 220/380В. Модели по приложению № 1, количество листов: 2

изготовитель "Motive srl". Место нахождения и адрес места осуществления деятельности по изготовлению продукции: Via Le Ghiselle, 20 25014 Castenedolo (BS), Италия.

Продукция изготовлена в соответствии с Директивой 2014/35/EU "Низковольтное оборудование".

Код ТН ВЭД ЕАЭС 8501. Серийный выпуск

соответствует требованиям

ТР ТС 004/2011 "О безопасности низковольтного оборудования", утвержден Решением Комиссии Таможенного союза от 16 августа 2011 года № 768

Декларация о соответствии принята на основании

Протокола испытаний № 199-04/2020 от 14.04.2020 года, выданного Испытательной лабораторией Общество с ограниченной ответственностью Инновационный центр «Солибри», аттестат аккредитации РОСС RU.31857.04ИЛС0.00063, сроком действия до 17.06.2022 года.

Схема декларирования 1д

Дополнительная информация

ГОСТ 16264.1-2016 Двигатели асинхронные. Часть 1. Общие технические условия. Срок хранения (службы, годности) указан в прилагаемой к продукции товаросопроводительной и/или эксплуатационной документации.

Декларация о соответствии действительна с даты регистрации по 13.04.2025 включительно

(подпись)



М.П.

Шелест Александр Иосифович

(Ф.И.О. заявителя)

Регистрационный номер декларации о соответствии: ЕАЭС N RU Д-Т.НХ37.В.02083/20

Дата регистрации декларации о соответствии: 14.04.2020



KINGDOM OF SAUDI ARABIA

Product Conformity Programme

Statement for Registration

PCP Ref.no: **KSA R-205239**

Issued to: Motive Srl
Via Artigianale 110/112
25010 Montirone (BS)
Italy

Product: II-06 MOTORS Incl. GEARED MOTORS/DRIVES

Model/Type: See appendix (1 page/s)

Applicable standards/references: IEC 60034, IEC 72



Issued by:

Regional Licensing Centre
Europe, Middle East and Africa
Intertek Semko AB
06 November 2009



Pia Östgaard
Manager

This Statement for Registration is for the exclusive use of Intertek's Client and is provided pursuant to the agreement between Intertek and its Client. Intertek's responsibility and liability are limited to the terms and conditions of the agreement. Intertek assumes no liability to any part, other than to the Client in accordance with the agreement, for any loss, expense or damage occasioned by the use of this Statement for Registration. Only the Client is authorized to permit copying or distribution of this Statement for Registration and then only in its entirety. Any use of the Intertek name for the sale or advertisement of the tested material, product or service must first be approved in writing by Intertek.



TYPE APPROVAL CERTIFICATE
No. ELE012624CS

This is to certify that the product below is found to be in compliance with the applicable requirement of the RINA type approval system.

<i>Description</i>	Electric motor asynchronous three-phases
<i>Type</i>	DELPHI Series
<i>Applicant</i>	MOTIVE SRL VIA GHISELLE, 20 25014 Castenedolo (BS) ITALY
<i>Manufacturer</i>	MOTIVE SRL
<i>Place of manufacture</i>	VIA GHISELLE, 20 25014 Castenedolo (BS) ITALY
<i>Reference standards</i>	RINA Rules, Part C, Chap. 2, Sect. 4

Issued in **Genoa** on **April 23, 2024**. This Certificate is valid until **April 22, 2029**

RINA Services S.p.A.
Luigi Benedetti

This certificate consists of this page and 1 enclosure

RINA Services S.p.A.
Via Corsica, 12 - 16128 Genova
Tel +39 010 53851
Fax +39 010 5351000



Italia

CERTIFICATO

Nr. 50 100 1185 - Rev.010

Si attesta che / This is to certify that

IL SISTEMA QUALITÀ DI
THE QUALITY SYSTEM OF



motive

MOTIVE S.r.l.

SEDE LEGALE E OPERATIVA:
REGISTERED OFFICE AND OPERATIONAL SITE:

**VIA LE GHISSELLE 20
IT - 25014 CASTENEDOLO (BS)**

È CONFORME AI REQUISITI DELLA NORMA
HAS BEEN FOUND TO COMPLY WITH THE REQUIREMENTS OF

UNI EN ISO 9001:2015

QUESTO CERTIFICATO È VALIDO PER IL SEGUENTE CAMPO DI APPLICAZIONE
THIS CERTIFICATE IS VALID FOR THE FOLLOWING SCOPE

**Progettazione e fabbricazione di motori elettrici, riduttori
meccanici e inverter (IAF 18, 19)**

**Design and manufacture of electrical motors, mechanical gearboxes
and variable speed drives (IAF 18, 19)**



SGQ N° 049A

Membro degli Accordi di Mutuo Riconoscimento
EA, IAF e ILAC
Signatory of EA, IAF and ILAC Mutual
Recognition Agreements

Per l'Organismo di Certificazione
For the Certification Body
TÜV Italia S.r.l.

Validità / Validity

Dal / From: **2019-03-19**

Ai / To: **2022-03-02**

Data emissione / Issuing Date

Andrea Coscia
Direttore Divisione Business Assurance

2019-03-19

PRIMA CERTIFICAZIONE / FIRST CERTIFICATION: 2001-07-20
DATA DI SCADENZA DELL'ULTIMO CICLO DI CERTIFICAZIONE: 2019-03-02
EXPIRATION DATE OF THE LAST CERTIFICATION CYCLE: 2019-03-02

"LA VALIDITÀ DEL PRESENTE CERTIFICATO È SUBORDINATA A SORVEGLIANZA PERIODICA A 12 MESI E AL RISAME COMPLETO DEL SISTEMA DI GESTIONE AZIENDALE CON PERIODICITÀ TRIENNALE"

"THE VALIDITY OF THE PRESENT CERTIFICATE DEPENDS ON THE ANNUAL SURVEILLANCE EVERY 12 MONTHS AND ON THE COMPLETE REVIEW OF COMPANY'S MANAGEMENT SYSTEM AFTER THREE YEARS"

TÜV Italia S.r.l. • Gruppo TÜV SÜD • Via Carducci 125, Pal. 23 • 20099 Sesto San Giovanni (MI) • Italia • www.tuv.it

TÜV®

ZERTIFIKAT ◆ CERTIFICATE ◆ 認證證書 ◆ CERTIFICADO ◆ CERTIFICAT

10014001



Responsabilità del costruttore

Il costruttore declina ogni responsabilità in caso di:

- Uso dei motori contrario alle leggi nazionali sulla sicurezza e sull'infortunistica
- Mancata o errata osservanza delle istruzioni fornite nel presente manuale
- Difetti di alimentazione elettrica
- Modifiche o manomissioni del motore
- Operazioni eseguite da parte di personale non addestrato

La sicurezza dei motori è subordinata anche alla osservanza delle prescrizioni riportate nel presente manuale.

Leggere integralmente le istruzioni ed osservare tutte le precauzioni indicate ed in particolare occorre:

- Operare sempre nei limiti di impiego del motore
- Affidare le manutenzioni a personale qualificato
- Utilizzare esclusivamente ricambi originali

Attenzione! Le istruzioni riportate nel presente manuale non sostituiscono, ma compendiano gli obblighi della legislazione vigente sulle norme di sicurezza

Manufacturer liability

Motive disclaims all responsibility in case of:

- Use of the motors against national safety law
- Missing or wrong observance of the instructions provided in this manual
- Problems with the power supply
- Motor modifications or tampering
- Operations run by non-trained personnel

The safety in the motors is also due to the observance of the indications provided in this manual.

Read carefully the instructions and keep to all the recommended precautions, too. In particular it is necessary to:

- Work always within the operational limits
- Have maintenance done by qualified personnel
- Use only original spare parts

Warning! The instructions contained in this handbook do not substitute but summarize the duties derived from the regulations in force about safety.



Su www.motive.it, partendo dal nr di serie nella targa del riduttore, è possibile scaricare il Rapporto del collaudo finale di ogni unità.

On www.motive.it, using the serial number on the nameplate of the gearbox, it is possible to download the Final Test Report of each unit.

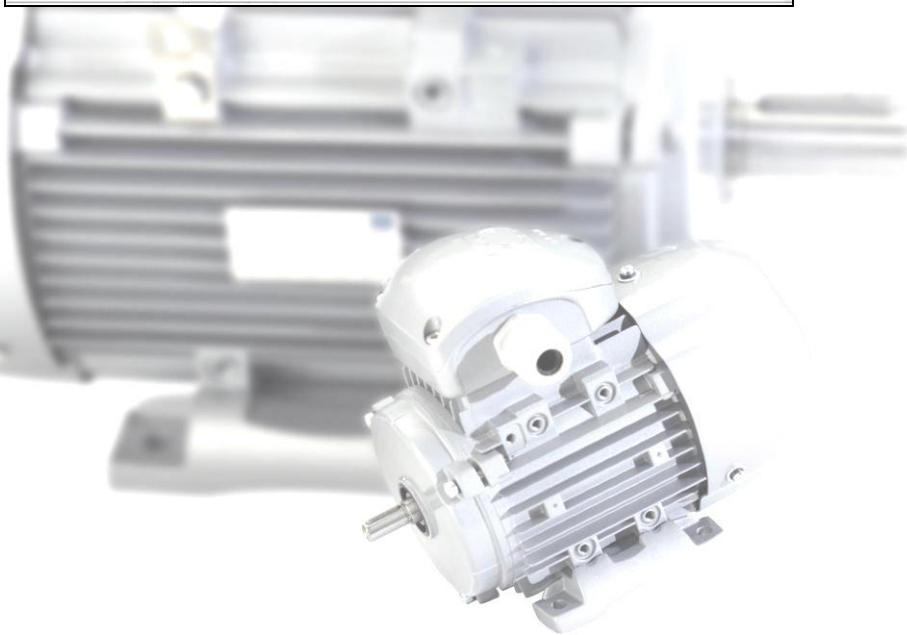



TUTTI I DATI SONO STATI REDATTI E CONTROLLATI CON LA MASSIMA CURA.
NON CI ASSUMIAMO COMUNQUE NESSUNA RESPONSABILITÀ PER EVENTUALI
ERRORI OD OMISSIONI.

MOTIVE srl PUÒ A SUO INSINDACABILE GIUDIZIO CAMBIARE IN QUALSIASI
MOMENTO LE CARATTERISTICHE DEI PRODOTTI VENDUTI.

ALL INFORMATION HAVE BEEN DRAWN AND CONTROLLED WITH THE MAXIMUM
CARE. HOWEVER, WE ARE NOT RESPONSIBLE FOR EVENTUAL ERRORS OR
MISSING INFORMATION

MOTIVE srl CAN CHANGE IN ANY MOMENT THE CHARACTERISTICS OF ITS
PRODUCTS



**PER MOTORI ATEX, VEDI L'INTEGRAZIONE
"ADDENDUM"**



**FOR ATEX MOTORS, THE "ADDENDUM"
FILE COMPLETES THIS MANUAL**

MADE IN ITALY

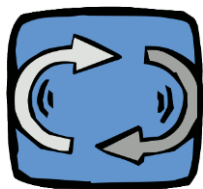

motive

®

Motive srl

www.motive.it

motive@motive.it

Tel: +39 030 2677087

Fax: +39 030 2677125

